

# HPC User Environment 1

Siva Prasad Kasetti

HPC User Services  
LSU HPC / LONI  
[sys-help@loni.org](mailto:sys-help@loni.org)

Louisiana State University  
Baton Rouge  
January 29, 2025

- **HPC User Environment 1**

1. An Intro to HPC
2. Accounts and allocations
3. Introduction to the cluster
4. Software environment (modules)

- **HPC User Environment 2**

1. Queuing system
2. How to run jobs

- **HPC User Environment 1**

1. An Intro to HPC
  - 1) Why HPC?
  - 2) What is HPC?
  - 3) Our HPC
2. Getting started
  - 1) Accounts
  - 2) Allocation
3. Into the cluster
  - 1) Getting connected
  - 2) File system
4. Software environment
  - 1) Preinstalled (modules)
  - 2) User installation

- **HPC User Environment 1**

1. Intro to HPC
  - 1) Why HPC?
  - 2) What is HPC?
  - 3) Our HPC
2. Getting started
  - 1) Accounts
  - 2) Allocation
3. Into the cluster
  - 1) Getting connected
  - 2) File system
4. Software environment
  - 1) Preinstalled (modules)
  - 2) User installation



Climate Modeling



Data Analysis

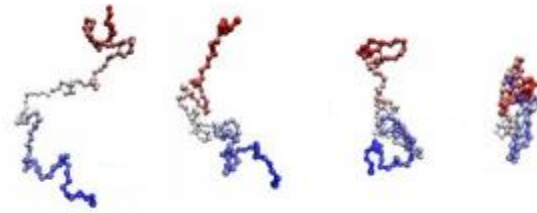

Protein folding



Drug Discovery



Artificial Intelligence



Energy Research

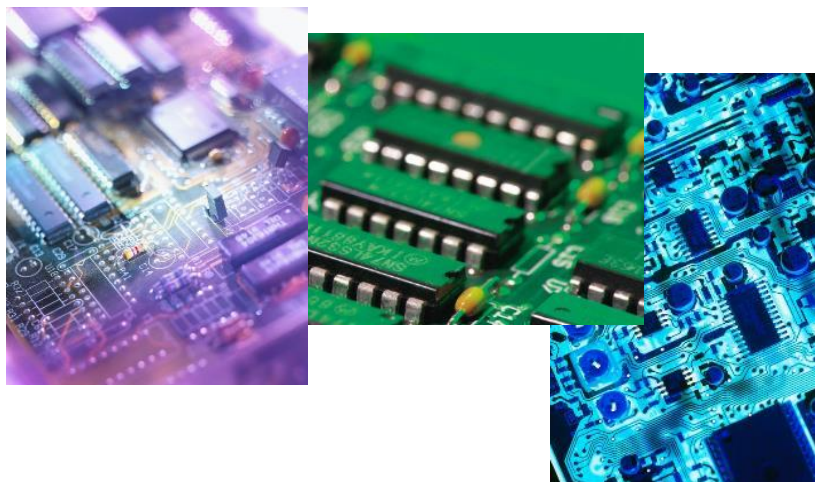

Computer runs one program at a time.

programs

input

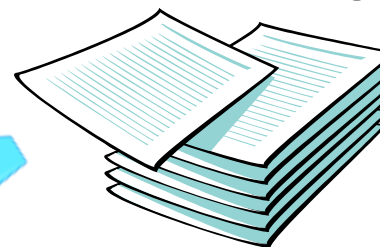

output

*Can we have something that just run 100x faster?*

# The von Neumann Architecture

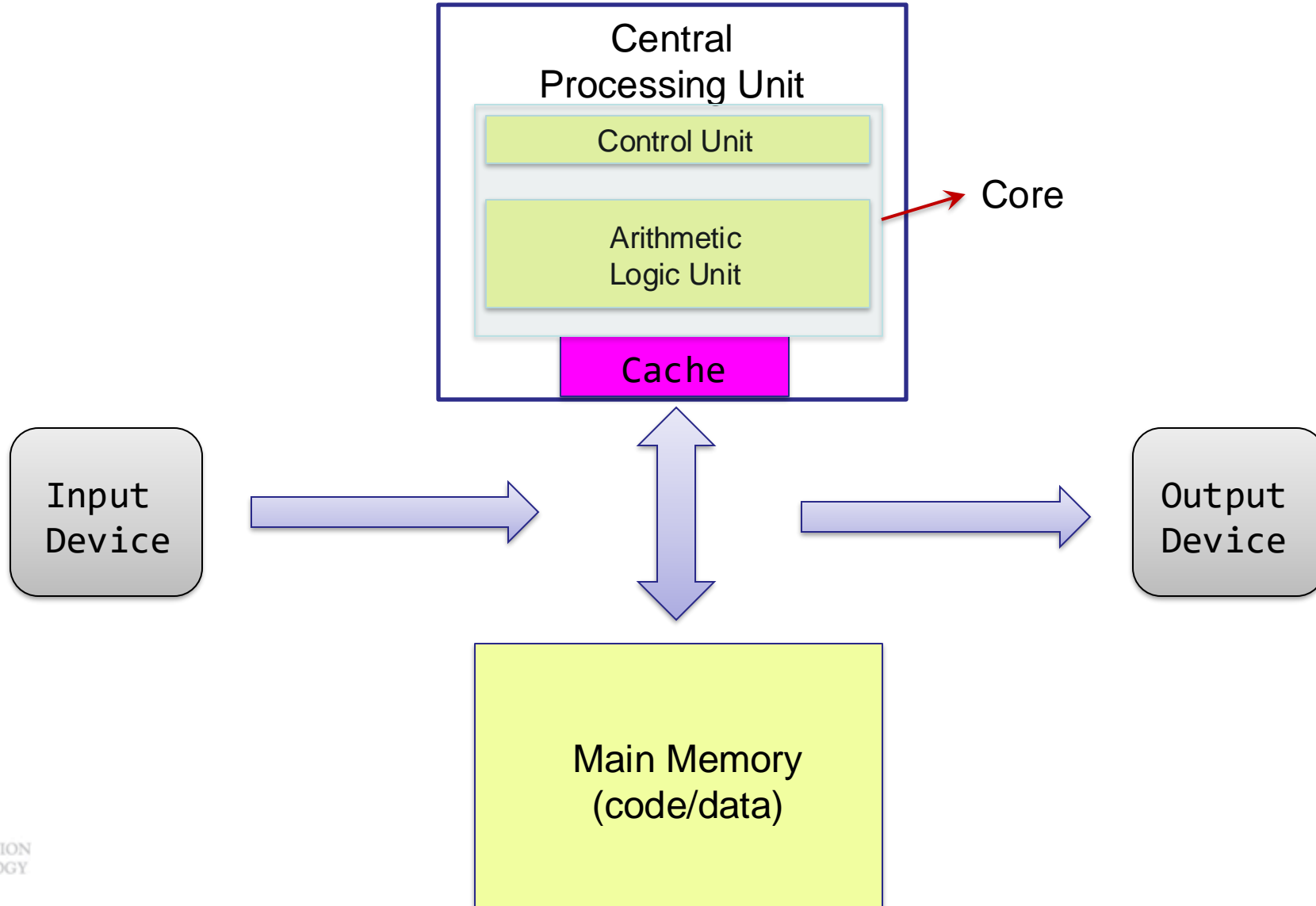

- From 1986 - 2002, microprocessors were speeding like a rocket, increasing in performance an average of 50% per year.
- Since then, it's dropped to about 20% increase per year.

## History of Processor Performance

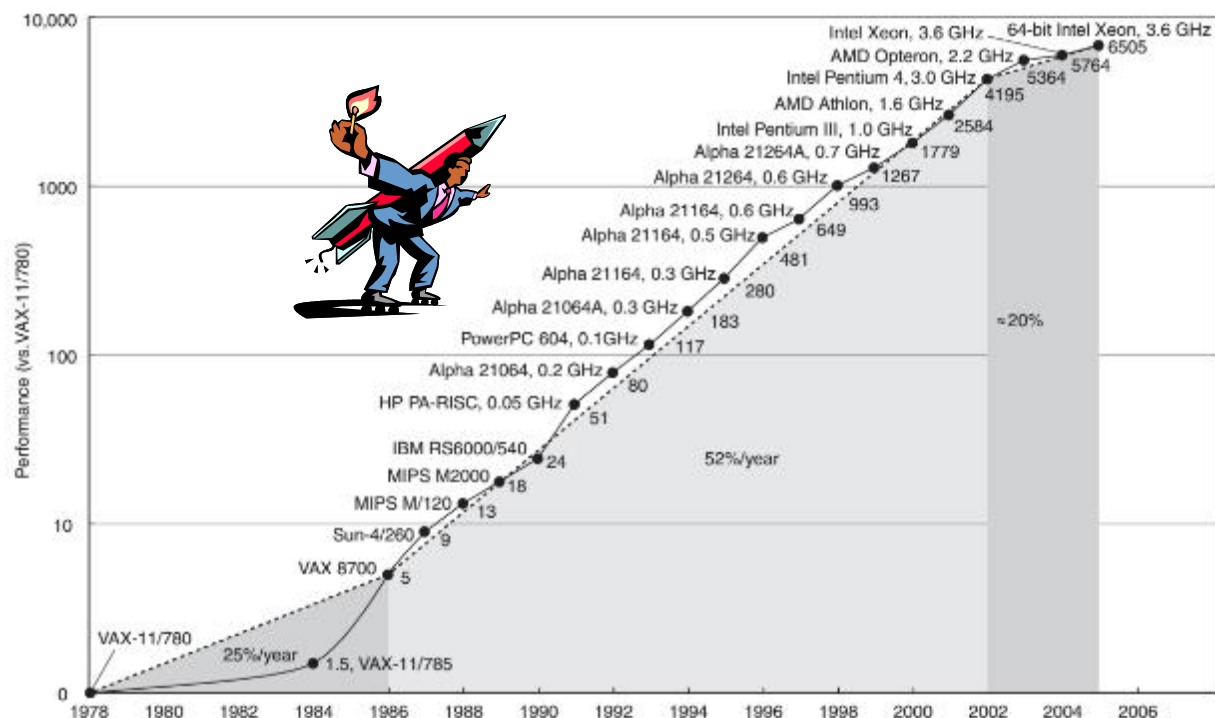

Limitation:

2 GHz Consumer  
4 GHz Server

Source:

<http://www.cs.columbia.edu/~sedwards/classes/2012/3827-spring/>



- **Smaller transistors = faster processors.**
- **Faster processors = increased power consumption.**
- **Increased power consumption = increased heat.**
- **Increased heat = unreliable processors.**
  
- **Solution:**
  - Move away from single-core systems to multicore processors.
  - “core” = central processing unit (CPU)
  - Introducing parallelism
    - *What if your problem is also not CPU dominant?*

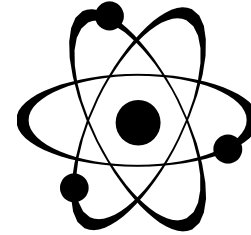

# The von Neumann Architecture

*Around year 2002*

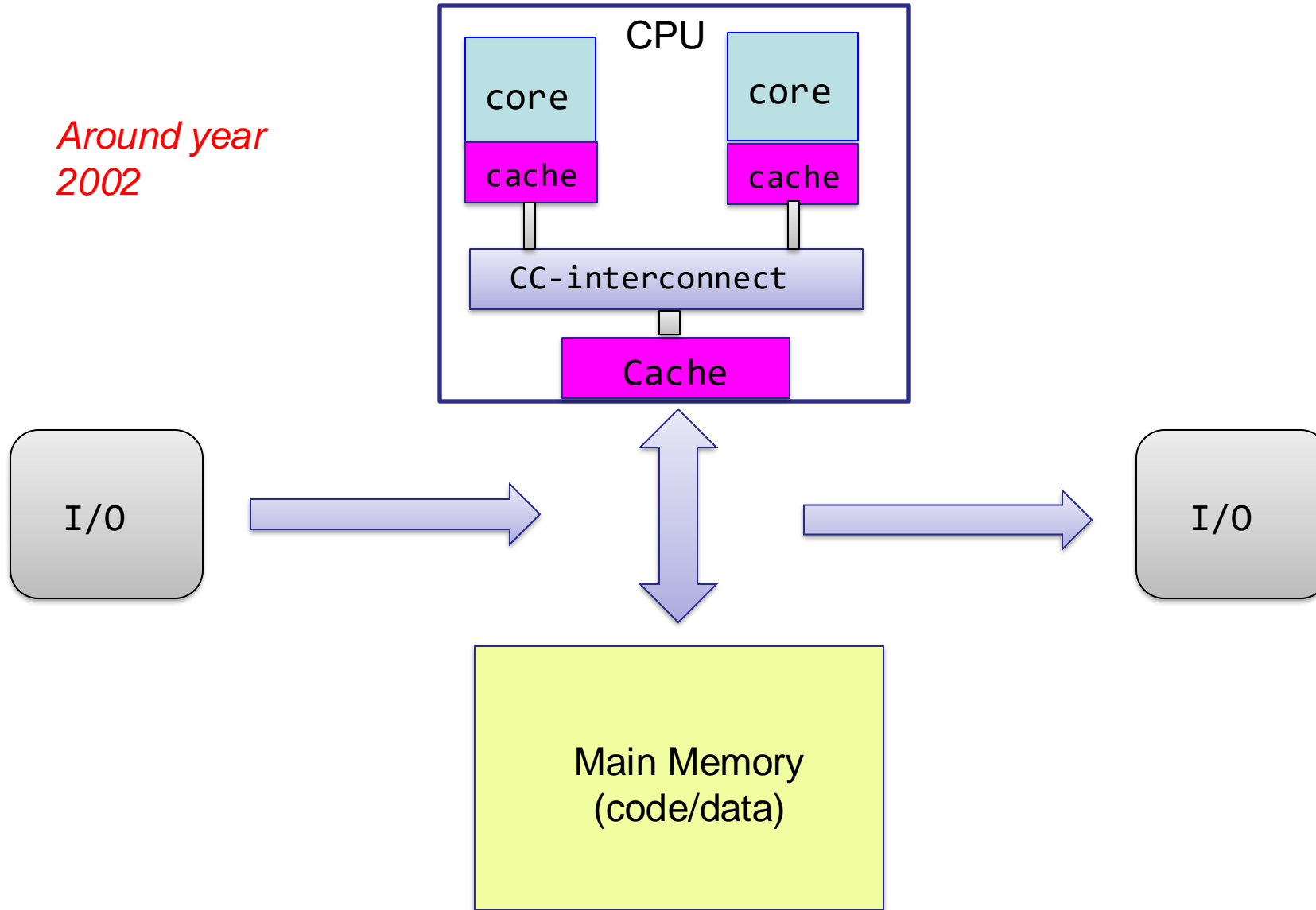

- Instead of designing and building faster microprocessors, put multiple processors on a single integrated circuit.

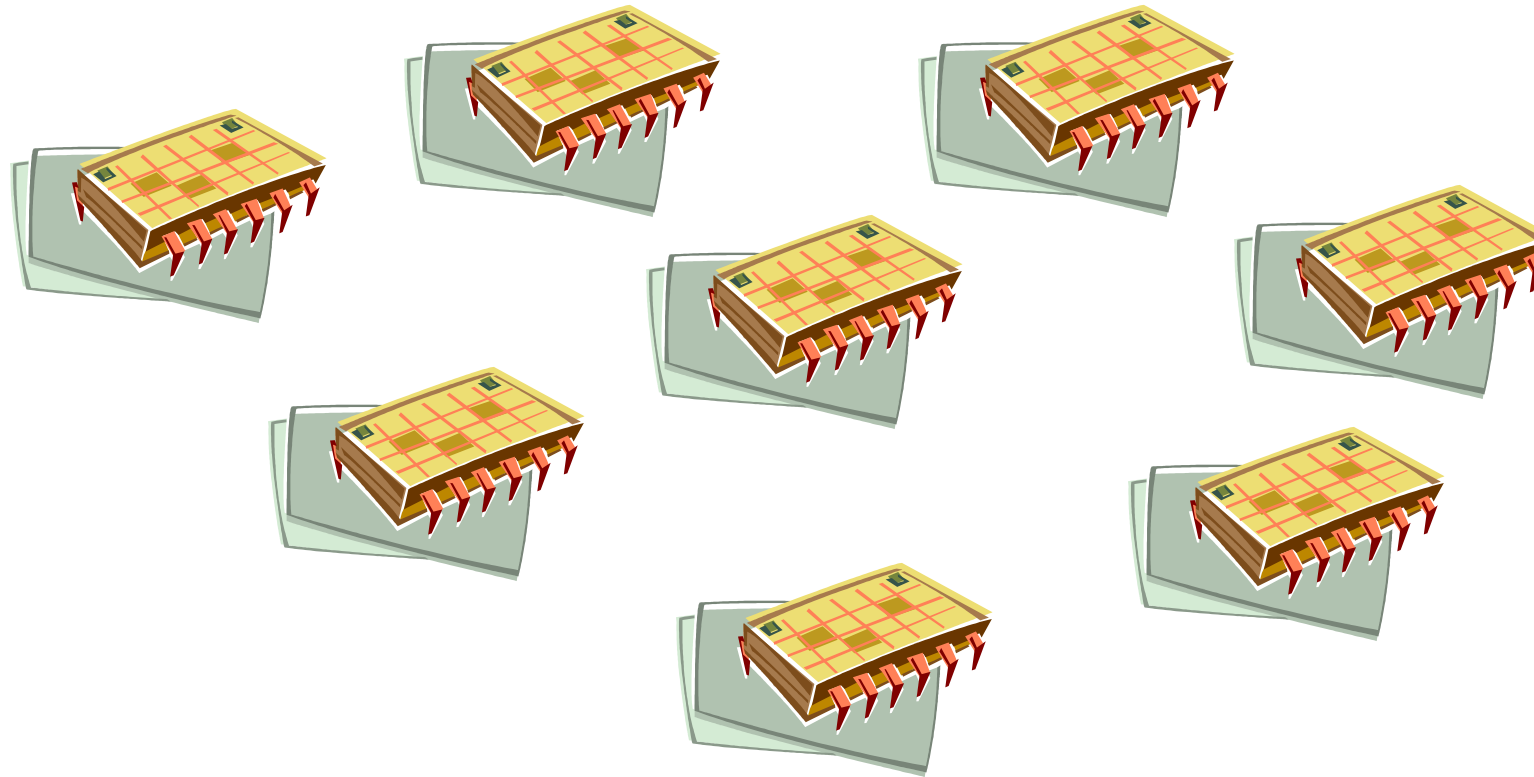

# 1) Why HPC?

- How many cores does this computer have?

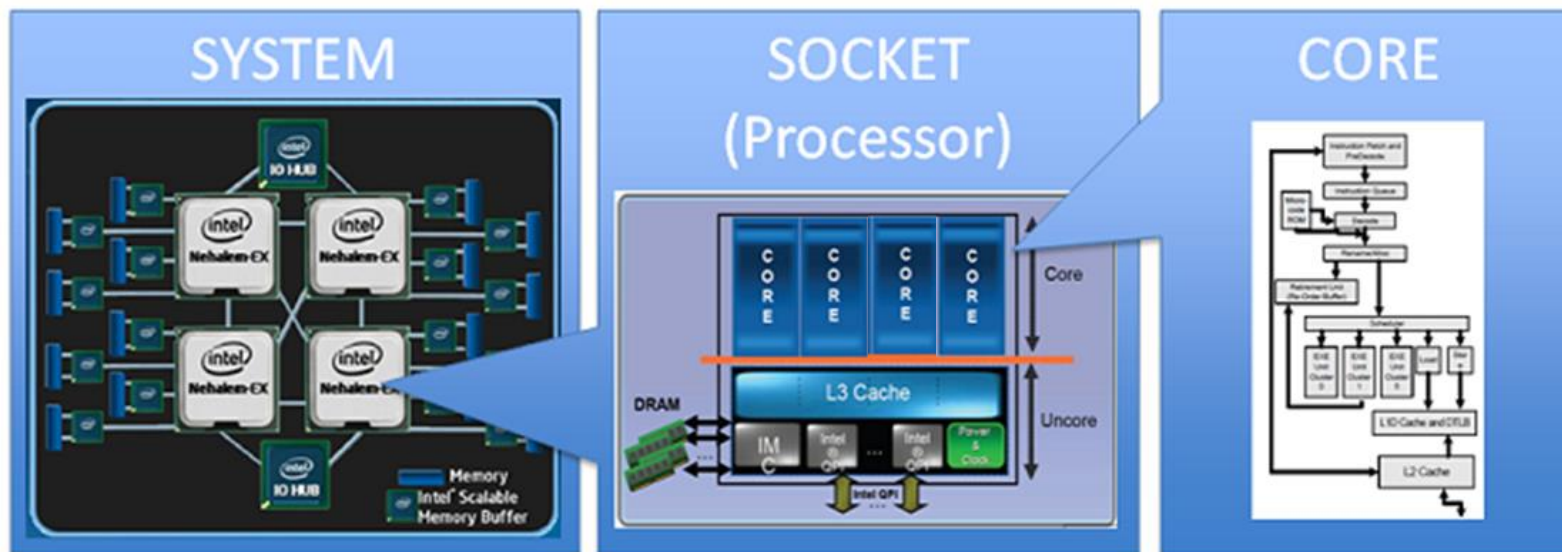

4 cores \* 4 processors = **16** total cores

- The laws of physics have brought us to the multi-core era.
- Serial programs typically don't benefit from the multi-core architecture.
- In order to get speedup, your code needs to be able to make use of multiple cores.

# 1) Why HPC?

- Everything **COMPUTER!**

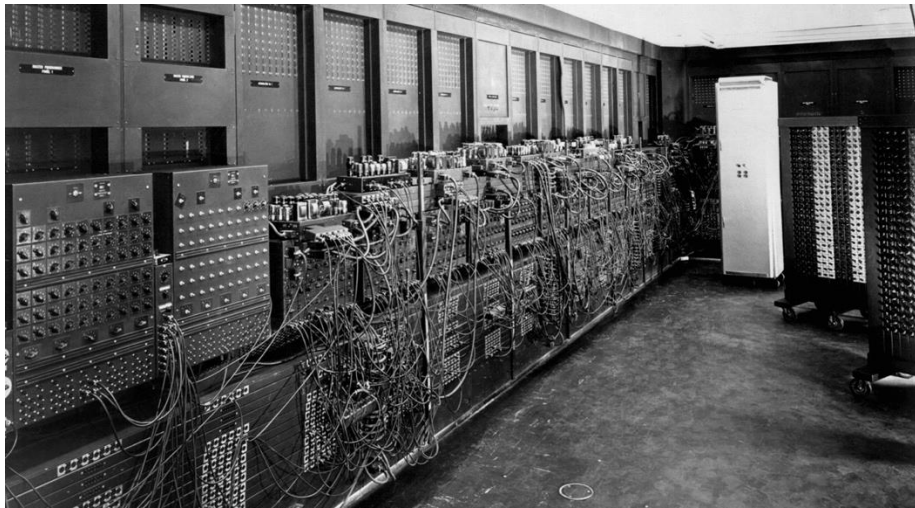

ENIAC, 1945

First all-vacuum tube supercomputer (18000 vacuum tubes), a decimal computer, hard-wired program with dials and switches.

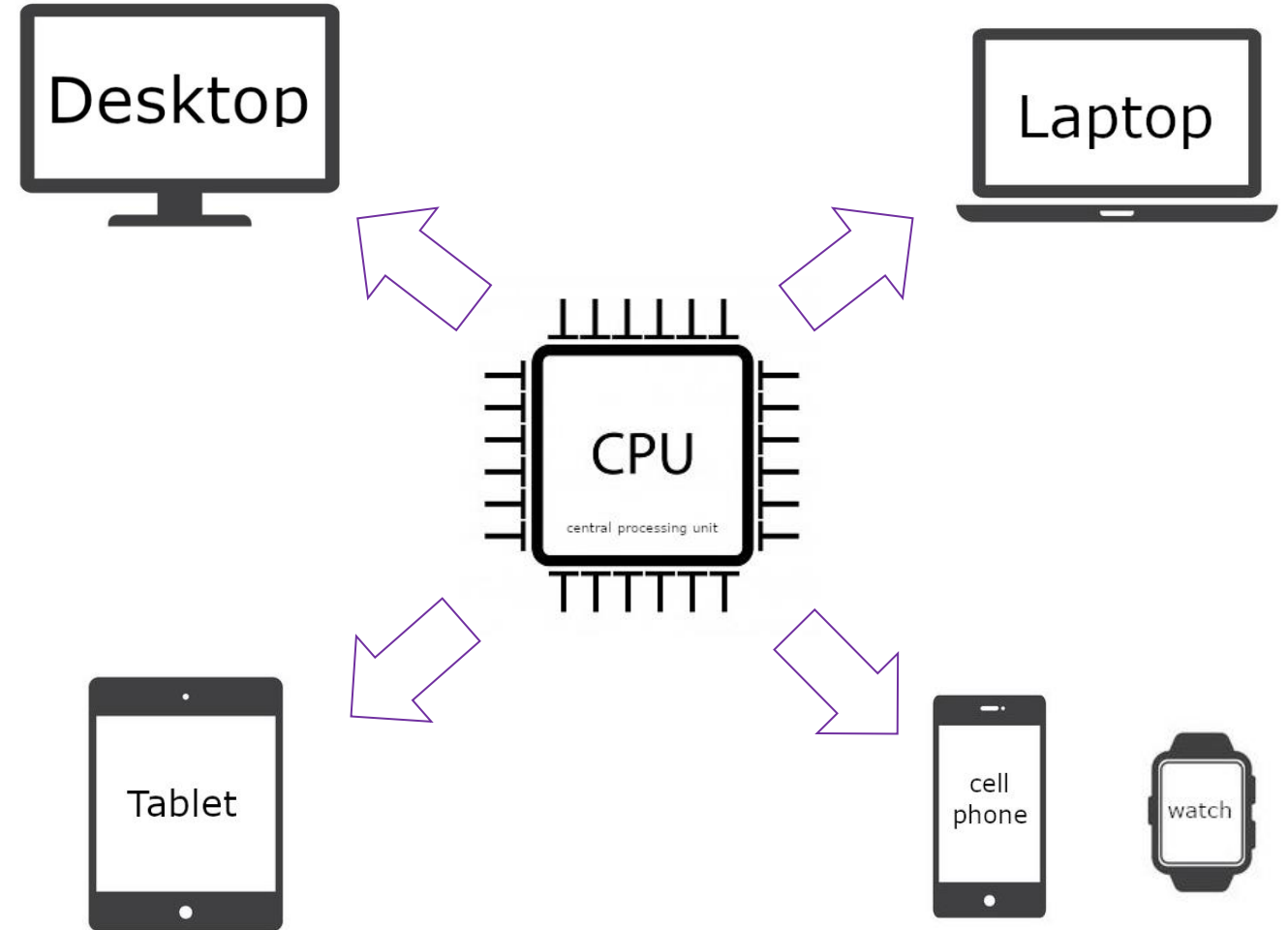

- **HPC User Environment 1**
  1. Intro to HPC
    - 1) Why HPC?
    - 2) What is HPC?
    - 3) Our HPC
  2. Getting started
    - 1) Accounts
    - 2) Allocation
  3. Into the cluster
    - 1) Getting connected
    - 2) File system
  4. Software environment
    - 1) Preinstalled (modules)
    - 2) User installation

## 2) What is HPC?

- **High Performance Computing (HPC):** the ability to process data and perform complex calculations at high speeds using the cutting-edge modern technology.
- **Supercomputer:** the class of machines that rank among the fastest in the world.
  - Rule of thumb: at least 100 times as powerful as a single PC.



600 mph



60 mph

How do we evaluate the performance of supercomputer?



# 2) What is HPC?

- Performance is measured in **Floating Point Operations Per Second (FLOPS)**

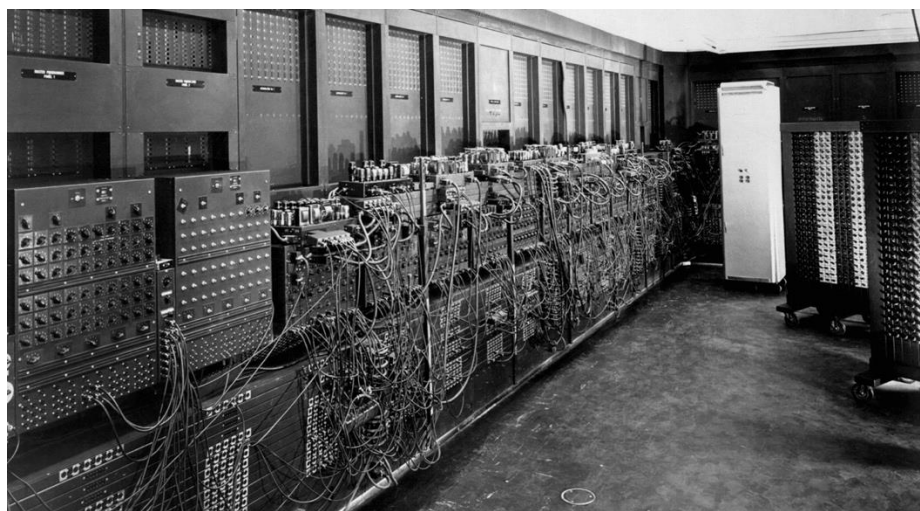

ENIAC FLOPS: **500**

$$FLOPS = cores \times clock \times \frac{FLOPs}{cycle}$$

↓                      ↓                      ↓                      ↓

**1267 GHz**      18      4.4 GHz      16

**1.27 TFLOPS**

Computer performance	
Name	FLOPS
yottaFLOPS	10 <sup>24</sup>
zettaFLOPS	10 <sup>21</sup>
exaFLOPS	10 <sup>18</sup>
petaFLOPS	10 <sup>15</sup>
teraFLOPS	10 <sup>12</sup>
gigaFLOPS	10 <sup>9</sup>
megaFLOPS	10 <sup>6</sup>
kiloFLOPS	10 <sup>3</sup>

“The first teraflop desktop PC: Intel i97980XE (Sep 2017)”

CPU clock rate: 4.4 GHz  
CORE: 18 cores  
FLOPs per cycle: 16



# 2) What is HPC?

- Your smartphone vs. supercomputer 24 and 30 years ago

- Apple A17 Pro (Hexa-core, 3.78 GHz): ~**17 TFLOPS**
- #1 ASCI WHITE, SP POWER3 375 MHz: **7.3 (12.3) TFLOPS**  
Total Cores: **8,192**, OS: **AIX**; Vendor: **IBM (2000)**
- #1 Fujitsu 105MHz: **0.2 (0.4) TFLOPS**  
Total Cores: **140**, OS: **UXP/V**; Vendor: **Fujitsu (1994)**

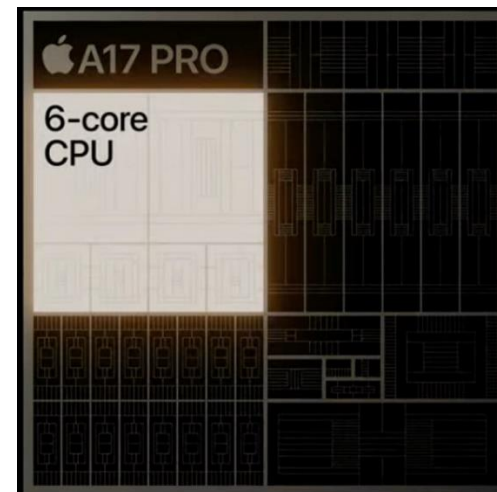

**CPU clock rate:** 3.78 GHz  
**CORE:** 6 cores  
**Transistors:** 19 billion  
**Technology:** 4 nm  
**OS system:** iOS

### Computer performance

Name	FLOPS
yottaFLOPS	$10^{24}$
zettaFLOPS	$10^{21}$
exaFLOPS	$10^{18}$
petaFLOPS	$10^{15}$
teraFLOPS	$10^{12}$
gigaFLOPS	$10^9$
megaFLOPS	$10^6$
kiloFLOPS	$10^3$

## iPhone 15 Pro (2023)

[1] iPhone 15 — September 22, [https://en.wikipedia.org/wiki/iPhone\\_15\\_Pro](https://en.wikipedia.org/wiki/iPhone_15_Pro)

[2] Top 500 list, <https://www.top500.org/lists/top500/2022/11/>

# 2) What is HPC?



Current (July 2024):

Rank	System	Cores	Rmax (PFlop/s)	Rpeak (PFlop/s)	Power (kW)
1	<a href="#">Frontier - HPE Cray EX235a, AMD Optimized 3rd Generation EPYC 64C 2GHz, AMD Instinct MI250X, Slingshot-11, HPE (2021)</a> <a href="#">DOE/SC/Oak Ridge National Laboratory</a> United States	8,699,904	1,206	1,714	22786
2	<a href="#">Aurora - HPE Cray EX - Intel Exascale Compute Blade, Xeon CPU Max 9470 52C 2.4GHz, Intel Data Center GPU Max, Slingshot-11, Intel</a> <a href="#">DOE/SC/Argonne National Laboratory</a> United States	9,264,128	1,012	1,980	38,698
3	<a href="#">Eagle - Microsoft NDv5, Xeon Platinum 8480C 48C 2GHz, NVIDIA H100, NVIDIA Infiniband NDR, Microsoft Azure</a> <a href="#">Microsoft Azure</a> United States	2,073,600	561	846	

# 2) What is HPC?



Current (July 2024):

Rank	System	Cores	Rmax (PFlop/s)	Rpeak (PFlop/s)	Power (kW)
1	<a href="#">Frontier - HPE Cray EX235a, AMD Optimized 3rd Generation EPYC 64C 2GHz, AMD Instinct MI250X, Slingshot-11, HPE (2021)</a> <a href="#">DOE/SC/Oak Ridge National Laboratory</a> United States	8,699,904	1,206	1,714	22786
2	<a href="#">Aurora - HPE Cray EX - Intel Exascale Compute Blade, Xeon CPU Max 9470 52C 2.4GHz, Intel Data Center GPU Max, Slingshot-11, Intel</a> <a href="#">DOE/SC/Argonne National Laboratory</a> United States	9,264,128	1,012	1,980	38,698
3	<a href="#">Eagle - Microsoft NDv5, Xeon Platinum 8480C 48C 2GHz, NVIDIA H100, NVIDIA Infiniband NDR, Microsoft Azure</a> <a href="#">Microsoft Azure</a> United States	2,073,600	561	846	

[1] Top 500 list, <https://top500.org/lists/top500/2024/06/>



## 2) What is HPC?



June 2019:

Rank	System	Cores	Rmax (PFlop/s)	Rpeak (PFlop/s)	Power (kW)
474	<a href="#">QB-2 - Dell C8220X Cluster, Intel Xeon E5-2680v2 10C 2.8GHz, Infiniband FDR, NVIDIA K20x, DELL EMC Louisiana Optical Network Initiative</a> United States	23,040	1.05	1.47	500



## 2) What is HPC?

- Inside a cluster:



## 2) What is HPC?

- Inside a rack:

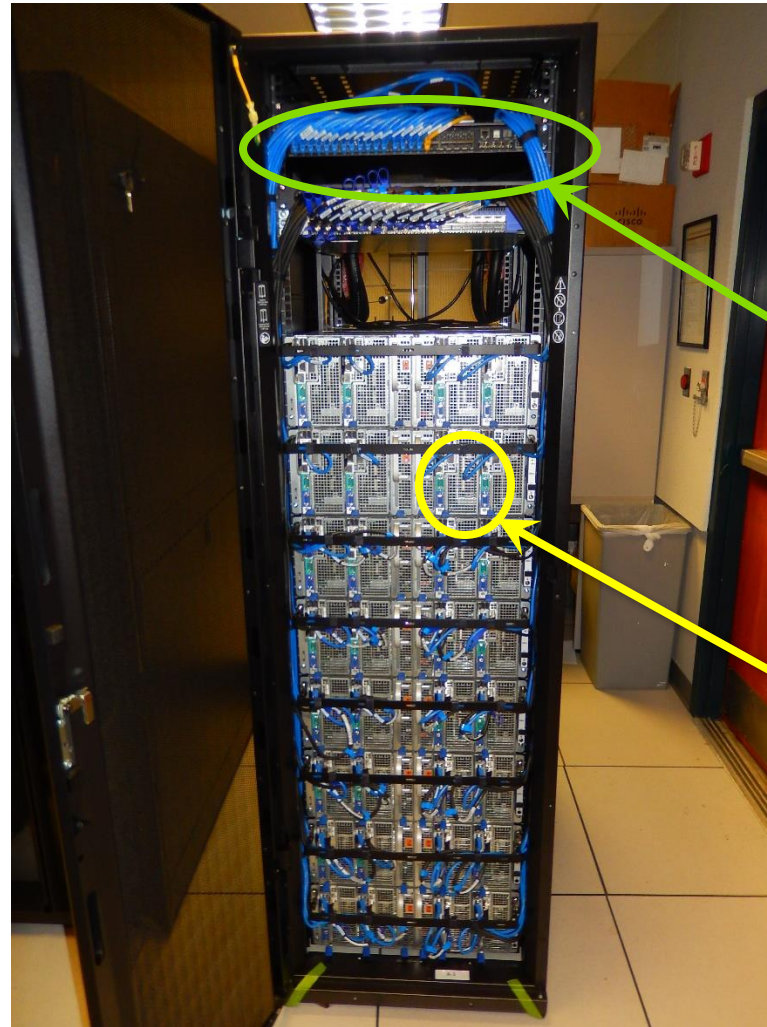

Interconnect:  
Infiniband  
Switch

Compute  
Node

## 2) What is HPC?

- Inside a node:

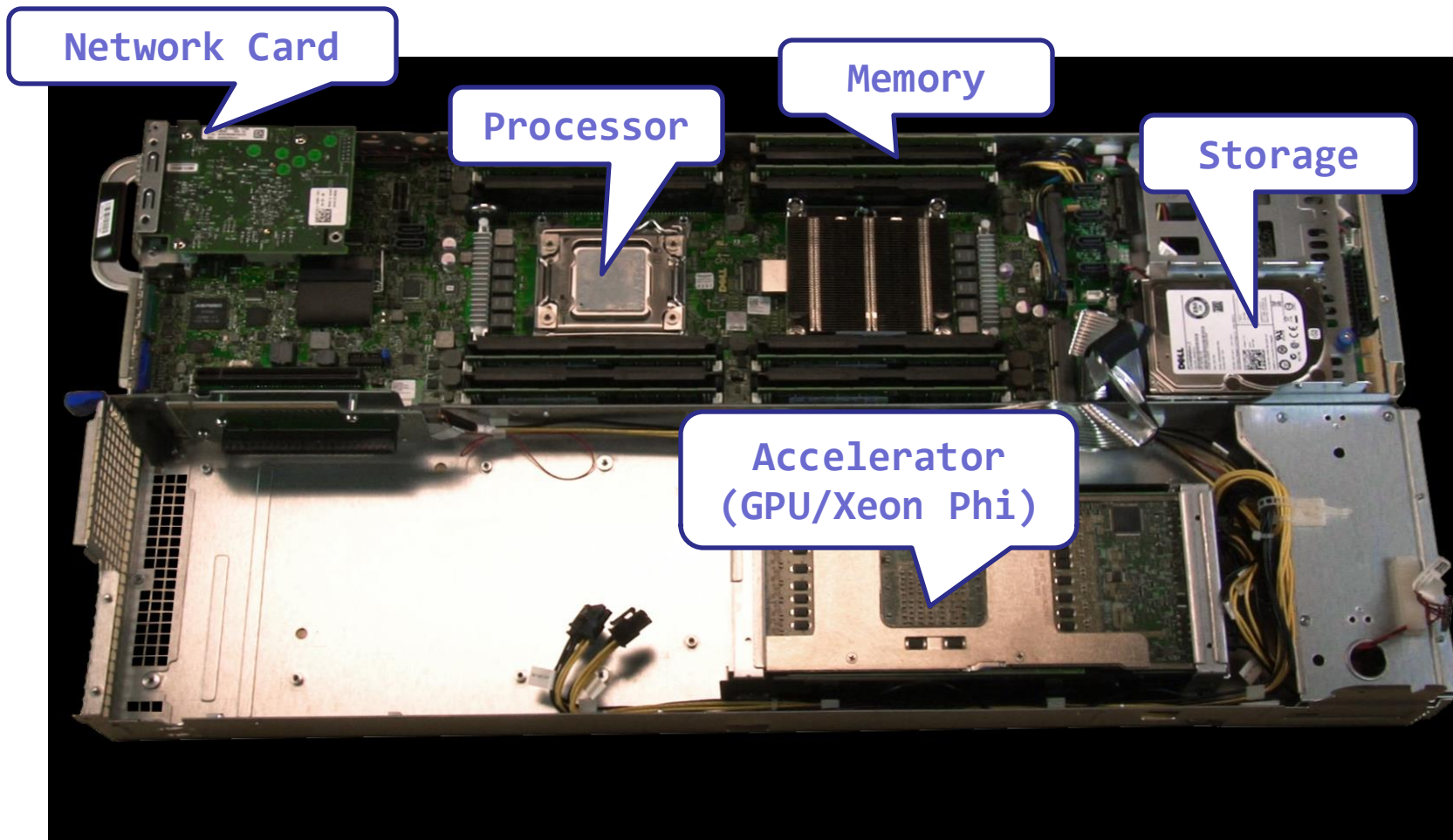



- **HPC User Environment 1**

1. Intro to HPC

- 1) Why HPC?
- 2) What is HPC?
- 3) **Our HPC**

2. Getting started

- 1) Accounts
- 2) Allocation

3. Into the cluster

- 1) Getting connected
- 2) File system

4. Software environment

- 1) Preinstalled (modules)
- 2) User installation

# 3) Our HPC

- i. University level: **LSU HPC**
- ii. State level: **LONI**
- iii. National level: **ACCESS**

Universities of  
Louisiana State



Louisiana State  
University Campus,  
Baton Rouge, LA



Advancing  
Innovation

Universities of the United States

i. **University level: LSU HPC**

- Available to **LSU (Baton Rouge campus) Faculty** and their **affiliates**
- Administered & supported by HPC@LSU



HPC HPC HPC HIGH PERFORMANCE COMPUTING

## i. University level: **LSU HPC**

SuperMIC	
Hostname	smic.hpc.lsu.edu
Peak Performance/TFlops	925
Compute nodes	360
Processor/node	2 10-core
Processor Speed	2.8 GHz
Processor Type	Intel Xeon 64bit
Nodes with Accelerators	360
Accelerator Type	Xeon Phi 7120P
OS	RHEL v6
Vendor	
Memory per node	64 GB
<a href="#">Detailed Cluster Description</a>	
<a href="#">User Guide</a>	
<a href="#">Available Software</a>	

Deep Bayou	
Hostname	db1.lsu.edu
Peak Performance/TFlops	257
Compute nodes	13
Processor/node	2 24-core
Processor Speed	2.4 GHz
Processor Type	Intel Cascade Lake Xeon 64bit
Nodes with Accelerators	13
Accelerator Type	2 x NVIDIA Volta V100S
OS	RHEL v7
Vendor	Dell
Memory per node	192 GB
<a href="#">Detailed Cluster Description</a>	
<a href="#">User Guide</a>	
<a href="#">Available Software</a>	

SuperMike III	
Hostname	mike.hpc.lsu.edu
Peak Performance/TFlops	1,285
Compute nodes	183
Processor/node	2 32-core
Processor Speed	2.6GHz
Processor Type	Intel Xeon Ice Lake
Nodes with Accelerators	8
Accelerator Type	4 NVIDIA A100
OS	RHEL v8
Vendor	Dell
Memory per node	256/2048 GB
<a href="#">Detailed Cluster Description</a>	
<a href="#">User Guide</a>	
<a href="#">Available Software</a>	

[1] <http://www.hpc.lsu.edu/resources/hpc/index.php#lsuhpc>



## i. University level: **LSU HPC**

SuperMIC	
Hostname	smic.hpc.lsu.edu
Peak Performance/TFlops	925
Compute nodes	360
Processor/node	2 10-core
Processor Speed	2.8 GHz
Processor Type	Intel Xeon 64bit
Nodes with Accelerators	360
Accelerator Type	Xeon Phi 7120P
OS	RHEL v6
Vendor	
Memory per node	64 GB
<a href="#">Detailed Cluster Description</a>	
<a href="#">User Guide</a>	
<a href="#">Available Software</a>	

Deep Bayou	
Hostname	db1.lsu.edu
Peak Performance/TFlops	257
Compute nodes	13
Processor/node	2 24-core
Processor Speed	2.4 GHz
Processor Type	Intel Cascade Lake Xeon 64bit
Nodes with Accelerators	13
Accelerator Type	2 x NVIDIA Volta V100S
OS	RHEL v7
Vendor	Dell
Memory per node	192 GB
<a href="#">Detailed Cluster Description</a>	
<a href="#">User Guide</a>	
<a href="#">Available Software</a>	

SuperMike III	
Hostname	mike.hpc.lsu.edu
Peak Performance/TFlops	1,285
Compute nodes	183
Processor/node	2 32-core
Processor Speed	2.6GHz
Processor Type	Intel Xeon Ice Lake
Nodes with Accelerators	8
Accelerator Type	4 NVIDIA A100
OS	RHEL v8
Vendor	Dell
Memory per node	256/2048 GB
<a href="#">Detailed Cluster Description</a>	
<a href="#">User Guide</a>	
<a href="#">Available Software</a>	

[1] <http://www.hpc.lsu.edu/resources/hpc/index.php#lsuhpc>



## i. University level: **LSU HPC**

SuperMIC	
Hostname	smic.hpc.lsu.edu
Peak Performance/TFlops	925
Compute nodes	360
Processor/node	2 10-core
Processor Speed	2.8 GHz
Processor Type	Intel Xeon 64bit
Nodes with Accelerators	360
Accelerator Type	Xeon Phi 7120P
OS	RHEL v6
Vendor	
Memory per node	64 GB
<a href="#">Detailed Cluster Description</a>	
<a href="#">User Guide</a>	
<a href="#">Available Software</a>	

Deep Bayou	
Hostname	db1.lsu.edu
Peak Performance/TFlops	257
Compute nodes	13
Processor/node	2 24-core
Processor Speed	2.4 GHz
Processor Type	Intel Cascade Lake Xeon 64bit
Nodes with Accelerators	13
Accelerator Type	2 x NVIDIA Volta V100S
OS	RHEL v7
Vendor	Dell
Memory per node	192 GB
<a href="#">Detailed Cluster Description</a>	
<a href="#">User Guide</a>	
<a href="#">Available Software</a>	

SuperMike III	
Hostname	mike.hpc.lsu.edu
Peak Performance/TFlops	1,285
Compute nodes	183
Processor/node	2 32-core
Processor Speed	2.6GHz
Processor Type	Intel Xeon Ice Lake
Nodes with Accelerators	8
Accelerator Type	4 NVIDIA A100
OS	RHEL v8
Vendor	Dell
Memory per node	256/2048 GB
<a href="#">Detailed Cluster Description</a>	
<a href="#">User Guide</a>	
<a href="#">Available Software</a>	

[1] <http://www.hpc.lsu.edu/resources/hpc/index.php#lsuhpc>



## i. University level: **LSU HPC**

SuperMIC	
Hostname	smic.hpc.lsu.edu
Peak Performance/TFlops	925
Compute nodes	360
Processor/node	2 10-core
Processor Speed	2.8 GHz
Processor Type	Intel Xeon 64bit
Nodes with Accelerators	360
Accelerator Type	Xeon Phi 7120P
OS	RHEL v6
Vendor	
Memory per node	64 GB
<a href="#">Detailed Cluster Description</a>	
<a href="#">User Guide</a>	
<a href="#">Available Software</a>	

Deep Bayou	
Hostname	db1.lsu.edu
Peak Performance/TFlops	257
Compute nodes	13
Processor/node	2 24-core
Processor Speed	2.4 GHz
Processor Type	Intel Cascade Lake Xeon 64bit
Nodes with Accelerators	13
Accelerator Type	2 x NVIDIA Volta V100S
OS	RHEL v7
Vendor	Dell
Memory per node	192 GB
<a href="#">Detailed Cluster Description</a>	
<a href="#">User Guide</a>	
<a href="#">Available Software</a>	

SuperMike III	
Hostname	mike.hpc.lsu.edu
Peak Performance/TFlops	1,285
Compute nodes	183
Processor/node	2 32-core
Processor Speed	2.6GHz
Processor Type	Intel Xeon Ice Lake
Nodes with Accelerators	8
Accelerator Type	4 NVIDIA A100
OS	RHEL v8
Vendor	Dell
Memory per node	256/2048 GB
<a href="#">Detailed Cluster Description</a>	
<a href="#">User Guide</a>	
<a href="#">Available Software</a>	

[1] <http://www.hpc.lsu.edu/resources/hpc/index.php#lsuhpc>



## i. University level: **LSU HPC**

SuperMIC	
Hostname	smic.hpc.lsu.edu
Peak Performance/TFlops	925
Compute nodes	360
Processor/node	2 10-core
Processor Speed	2.8 GHz
Processor Type	Intel Xeon 64bit
Nodes with Accelerators	360
Accelerator Type	Xeon Phi 7120P
OS	RHEL v6
Vendor	
Memory per node	64 GB
<a href="#">Detailed Cluster Description</a>	
<a href="#">User Guide</a>	
<a href="#">Available Software</a>	

Deep Bayou	
Hostname	db1.lsu.edu
Peak Performance/TFlops	257
Compute nodes	13
Processor/node	2 24-core
Processor Speed	2.4 GHz
Processor Type	Intel Cascade Lake Xeon 64bit
Nodes with Accelerators	13
Accelerator Type	2 x NVIDIA Volta V100S
OS	RHEL v7
Vendor	Dell
Memory per node	192 GB
<a href="#">Detailed Cluster Description</a>	
<a href="#">User Guide</a>	
<a href="#">Available Software</a>	

SuperMike III	
Hostname	mike.hpc.lsu.edu
Peak Performance/TFlops	1,285
Compute nodes	183
Processor/node	2 32-core
Processor Speed	2.6GHz
Processor Type	Intel Xeon Ice Lake
Nodes with Accelerators	8
Accelerator Type	4 NVIDIA A100
OS	RHEL v8
Vendor	Dell
Memory per node	256/2048 GB
<a href="#">Detailed Cluster Description</a>	
<a href="#">User Guide</a>	
<a href="#">Available Software</a>	

[1] <http://www.hpc.lsu.edu/resources/hpc/index.php#lsuhpc>





## i. University level: **LSU HPC**

SuperMIC	
Hostname	smic.hpc.lsu.edu
Peak Performance/TFlops	925
Compute nodes	360
Processor/node	2 10-core
Processor Speed	2.8 GHz
Processor Type	Intel Xeon 64bit
Nodes with Accelerators	360
Accelerator Type	Xeon Phi 7120P
OS	RHEL v6
Vendor	
Memory per node	64 GB
<a href="#">Detailed Cluster Description</a>	
<a href="#">User Guide</a>	
<a href="#">Available Software</a>	

Deep Bayou	
Hostname	db1.lsu.edu
Peak Performance/TFlops	257
Compute nodes	13
Processor/node	2 24-core
Processor Speed	2.4 GHz
Processor Type	Intel Cascade Lake Xeon 64bit
Nodes with Accelerators	13
Accelerator Type	2 x NVIDIA Volta V100S
OS	RHEL v7
Vendor	Dell
Memory per node	192 GB
<a href="#">Detailed Cluster Description</a>	
<a href="#">User Guide</a>	
<a href="#">Available Software</a>	

SuperMike III	
Hostname	mike.hpc.lsu.edu
Peak Performance/TFlops	1,285
Compute nodes	183
Processor/node	2 32-core
Processor Speed	2.6GHz
Processor Type	Intel Xeon Ice Lake
Nodes with Accelerators	8
Accelerator Type	4 NVIDIA A100
OS	RHEL v8
Vendor	Dell
Memory per node	256/2048 GB
<a href="#">Detailed Cluster Description</a>	
<a href="#">User Guide</a>	
<a href="#">Available Software</a>	

[1] <http://www.hpc.lsu.edu/resources/hpc/index.php#lsuhpc>



## i. University level: **LSU HPC**

SuperMIC	
Hostname	smic.hpc.lsu.edu
Peak Performance/TFlops	925
Compute nodes	360
Processor/node	2 10-core
Processor Speed	2.8 GHz
Processor Type	Intel Xeon 64bit
Nodes with Accelerators	360
Accelerator Type	Xeon Phi 7120P
OS	RHEL v6
Vendor	
Memory per node	64 GB
<a href="#">Detailed Cluster Description</a>	
<a href="#">User Guide</a>	
<a href="#">Available Software</a>	

Deep Bayou	
Hostname	db1.lsu.edu
Peak Performance/TFlops	257
Compute nodes	13
Processor/node	2 24-core
Processor Speed	2.4 GHz
Processor Type	Intel Cascade Lake Xeon 64bit
Nodes with Accelerators	13
Accelerator Type	2 x NVIDIA Volta V100S
OS	RHEL v7
Vendor	Dell
Memory per node	192 GB
<a href="#">Detailed Cluster Description</a>	
<a href="#">User Guide</a>	
<a href="#">Available Software</a>	

SuperMike III	
Hostname	mike.hpc.lsu.edu
Peak Performance/TFlops	1,285
Compute nodes	183
Processor/node	2 32-core
Processor Speed	2.6GHz
Processor Type	Intel Xeon Ice Lake
Nodes with Accelerators	8
Accelerator Type	4 NVIDIA A100
OS	RHEL v8
Vendor	Dell
Memory per node	256/2048 GB
<a href="#">Detailed Cluster Description</a>	
<a href="#">User Guide</a>	
<a href="#">Available Software</a>	

[1] <http://www.hpc.lsu.edu/resources/hpc/index.php#lsuhpc>



## i. University level: **LSU HPC**

SuperMIC	
Hostname	smic.hpc.lsu.edu
Peak Performance/TFlops	925
Compute nodes	360
Processor/node	2 10-core
Processor Speed	2.8 GHz
Processor Type	Intel Xeon 64bit
Nodes with Accelerators	360
Accelerator Type	Xeon Phi 7120P
OS	RHEL v6
Vendor	
Memory per node	64 GB
<a href="#">Detailed Cluster Description</a>	
<a href="#">User Guide</a>	
<a href="#">Available Software</a>	

Deep Bayou	
Hostname	db1.lsu.edu
Peak Performance/TFlops	257
Compute nodes	13
Processor/node	2 24-core
Processor Speed	2.4 GHz
Processor Type	Intel Cascade Lake Xeon 64bit
Nodes with Accelerators	13
Accelerator Type	2 x NVIDIA Volta V100S
OS	RHEL v7
Vendor	Dell
Memory per node	192 GB
<a href="#">Detailed Cluster Description</a>	
<a href="#">User Guide</a>	
<a href="#">Available Software</a>	

SuperMike III	
Hostname	mike.hpc.lsu.edu
Peak Performance/TFlops	1,285
Compute nodes	183
Processor/node	2 32-core
Processor Speed	2.6GHz
Processor Type	Intel Xeon Ice Lake
Nodes with Accelerators	8
Accelerator Type	4 NVIDIA A100
OS	RHEL v8
Vendor	Dell
Memory per node	256/2048 GB
<a href="#">Detailed Cluster Description</a>	
<a href="#">User Guide</a>	
<a href="#">Available Software</a>	

[1] <http://www.hpc.lsu.edu/resources/hpc/index.php#lsuhpc>



## i. University level: **LSU HPC**

SuperMIC	
Hostname	smic.hpc.lsu.edu
Peak Performance/TFlops	925
Compute nodes	360
Processor/node	2 10-core
Processor Speed	2.8 GHz
Processor Type	Intel Xeon 64bit
Nodes with Accelerators	360
Accelerator Type	Xeon Phi 7120P
OS	RHEL v6
Vendor	
Memory per node	64 GB
<a href="#">Detailed Cluster Description</a>	
<a href="#">User Guide</a>	
<a href="#">Available Software</a>	

Deep Bayou	
Hostname	db1.lsu.edu
Peak Performance/TFlops	257
Compute nodes	13
Processor/node	2 24-core
Processor Speed	2.4 GHz
Processor Type	Intel Cascade Lake Xeon 64bit
Nodes with Accelerators	13
Accelerator Type	2 x NVIDIA Volta V100S
OS	RHEL v7
Vendor	Dell
Memory per node	192 GB
<a href="#">Detailed Cluster Description</a>	
<a href="#">User Guide</a>	
<a href="#">Available Software</a>	

SuperMike III	
Hostname	mike.hpc.lsu.edu
Peak Performance/TFlops	1,285
Compute nodes	183
Processor/node	2 32-core
Processor Speed	2.6GHz
Processor Type	Intel Xeon Ice Lake
Nodes with Accelerators	8
Accelerator Type	4 NVIDIA A100
OS	RHEL v8
Vendor	Dell
Memory per node	256/2048 GB
<a href="#">Detailed Cluster Description</a>	
<a href="#">User Guide</a>	
<a href="#">Available Software</a>	

[1] <http://www.hpc.lsu.edu/resources/hpc/index.php#lsuhpc>



## ii. State level: **Louisiana Optical Network Infrastructure (LONI)**

- State-of-the-art fiber optic network
- Runs throughout Louisiana State, connects Louisiana and Mississippi State research universities.
- \$40M Optical Network, 10Gb Ethernet over fiber optics.
- Available to **LONI subscribers** and their **affiliates**
- Administered & supported by **HPC@LSU**



## ii. State level: Louisiana Optical Network Infrastructure (LONI)



## ii. State level: Louisiana Optical Network Infrastructure (LONI)

QB2	
Hostname	qb2.loni.org
Peak Performance/TFlops	1,500
Compute nodes	504
Processor/node	2 10-Core
Processor Speed	2.8GHz
Processor Type	Intel Ivy Bridge-EP Xeon 64bit
Nodes with Accelerators	480
Accelerator Type	NVIDIA Tesla K20x
OS	RHEL v6
Vendor	Dell
Memory per node	64 GB
Location	Information Systems Building, Baton Rouge
<a href="#">Detailed Cluster Description</a>	
<a href="#">User Guide</a>	
<a href="#">Available Software</a>	

QB3	
Hostname	qbc.loni.org
Peak Performance/TFlops	857
Compute nodes	202
Processor/node	2 24-Core
Processor Speed	2.4GHz
Processor Type	Intel Cascade Lake Xeon 64bit
Nodes with Accelerators	8
Accelerator Type	NVIDIA Volta V100
OS	RHEL v7
Vendor	Dell
Memory per node	192 GB
Location	Information Systems Building, Baton Rouge
<a href="#">Detailed Cluster Description</a>	
<a href="#">User Guide</a>	
<a href="#">Available Software</a>	

QB4	
Hostname	qbd.loni.org
Peak Performance/TFlops	4,300
Compute nodes	547
Processor/node	2 32-Core
Processor Speed	2.6GHz
Processor Type	Intel Ice Lake Xeon 64bit
Nodes with Accelerators	62
Accelerator Type	NVIDIA Ampere A100
OS	RHEL v8
Vendor	Dell
Memory per node	256/512/2048 GB
Location	Information Systems Building, Baton Rouge
<a href="#">Detailed Cluster Description</a>	
<a href="#">User Guide</a>	
<a href="#">Available Software</a>	

[1] <http://www.hpc.lsu.edu/resources/hpc/index.php#loni>



iii. **National level: Advanced Cyberinfrastructure Coordination Ecosystem: Services & Support (ACCESS)**

- NSF funded
- <https://access-ci.org/>



Advancing  
Innovation



- **Summary**

	<b>LSU HPC</b>	<b>LONI</b>
<b>Available to...</b>	LSU faculty & affiliates	LONI subscribers & affiliates
<b>Clusters</b>	SuperMIC Deep Bayou SuperMike III	QB2 QB3 QB4

# Questions?

- **HPC User Environment 1**

1. Intro to HPC
  - 1) Why HPC?
  - 2) What is HPC?
  - 3) Our HPC
2. **Getting started**
  - 1) Accounts
  - 2) Allocation
3. Intro the cluster
  - 1) Getting connected
  - 2) File system
4. Software environment
  - 1) Preinstalled (modules)
  - 2) User installation

**Two things are needed to run jobs on our clusters**

**1) Account**

**2) Allocation**

- **HPC User Environment 1**

1. Intro to HPC
  - 1) Why HPC?
  - 2) What is HPC?
  - 3) Our HPC
2. **Getting started**
  - 1) **Accounts**
  - 2) Allocation
3. Intro the cluster
  - 1) What users see?
  - 2) Useful commands & tools
4. Software environment
  - 1) Preinstalled (modules)
  - 2) User installation

	LSU HPC	LONI
Available to...	LSU faculty & affiliates	LONI subscribers & affiliates
Clusters	SuperMIC Deep Bayou SuperMike III	QB2 QB3 QB4

- LSU HPC & LONI: **distinct systems, distinct accounts**
- Having an account on one does **not** grant the user access to the other

## i. Eligibility (LSU HPC)

LSU HPC	
Available to...	
Requirements	

## i. Eligibility (LSU HPC)

LSU HPC	
Available to...	<ul style="list-style-type: none"><li>✓ Faculty of LSU Baton Rouge campus</li><li>✓ Research staff (postdocs, research associates, ...)</li><li>✓ Students (graduate &amp; undergraduate)</li><li>✓ Research collaborators (LSU &amp; non-LSU)</li><li>✓ Other affiliates</li></ul>
Requirements	



## i. Eligibility (LSU HPC)

LSU HPC	
Available to...	<ul style="list-style-type: none"><li>✓ Faculty of LSU Baton Rouge campus</li><li>✓ Research staff (postdocs, research associates, ...)</li><li>✓ Students (graduate &amp; undergraduate)</li><li>✓ Research collaborators (LSU &amp; non-LSU)</li><li>✓ Other affiliates</li></ul>
Requirements	<ul style="list-style-type: none"><li>• <b>Institutional email</b> (e.g., @lsu.edu)</li><li>• <b>Account sponsor / PI</b><ul style="list-style-type: none"><li>✓ <u>Full-time faculty &amp; certain research staff @ LSU Baton Rouge campus</u></li><li>× Students, postdocs, research associates (even @ LSU)</li><li>× Outside collaborators</li><li>× HPC staff</li></ul></li></ul>

## i. Eligibility (LSU HPC)

You are a ...	Your account sponsor
Full-time faculty @ LSU Baton Rouge campus	Yourself
Graduate student @ LSU doing research	Your advisor
Outside collaborator	Your LSU collaborator (full-time faculty)
LSU student taking a course that requires HPC	Your instructor (full-time faculty)
REU student working @ LSU	Your LSU advisor (full-time faculty)

## i. Eligibility (LONI)

LONI	
Available to...	<ul style="list-style-type: none"><li>✓ Faculty of LONI subscribers</li><li>✓ Research staff (postdocs, research associates, ...)</li><li>✓ Students (graduate &amp; undergraduate)</li><li>✓ Research collaborators (@ LONI subscribers / outside)</li><li>✓ Other affiliates</li></ul>
Requirements	<ul style="list-style-type: none"><li>• <b>Institutional email</b> (e.g., @uno.edu)</li><li>• <b>Account sponsor / PI</b><ul style="list-style-type: none"><li>✓ <u>Full-time faculty @ LONI subscribers</u></li><li>× Students, postdocs, research associates (even @ LONI subscribers)</li><li>× Outside collaborators</li><li>× HPC staff</li></ul></li></ul>

## i. Eligibility (LONI)

You are a ...	Your account sponsor
Full-time faculty @ LONI subscribers	Yourself
Graduate student during research	Your advisor (faculty @ LONI subscribers)
Outside collaborator	Your collaborator (faculty @ LONI subscribers)
Student taking a course that requires HPC	Your instructor (faculty @ LONI subscribers)
REU student	Your advisor (faculty @ LONI subscribers)

## i. Eligibility (Summary)

	LSU HPC	LONI
<b>Available to...</b>	<ul style="list-style-type: none"> <li>✓ Faculty of LSU Baton Rouge campus</li> <li>✓ Research staff (postdocs, research associates, ...)</li> <li>✓ Students (graduate &amp; undergraduate)</li> <li>✓ Research collaborators (LSU &amp; non-LSU)</li> <li>✓ Other affiliates</li> </ul>	<ul style="list-style-type: none"> <li>✓ Faculty of LONI subscribers</li> <li>✓ Research staff (postdocs, research associates, ...)</li> <li>✓ Students (graduate &amp; undergraduate)</li> <li>✓ Research collaborators</li> <li>✓ Other affiliates</li> </ul>
<b>Requirements</b>	<ul style="list-style-type: none"> <li>• <b>Institutional email</b> (e.g., @lsu.edu)</li> <li>• <b>Account sponsor / PI</b> <ul style="list-style-type: none"> <li>✓ <u>Full-time faculty &amp; certain research staff @ LSU Baton Rouge campus</u></li> <li>× Students, postdocs, research associates (even @ LSU)</li> <li>× Outside collaborators</li> <li>× HPC staff</li> </ul> </li> </ul>	<ul style="list-style-type: none"> <li>• <b>Institutional email</b> (e.g., @uno.edu)</li> <li>• <b>Account sponsor / PI</b> <ul style="list-style-type: none"> <li>✓ <u>Full-time faculty &amp; certain research staff @ LONI subscribers</u></li> <li>× Students, postdocs, research associates (even @ LONI subscribers)</li> <li>× Outside collaborators</li> <li>× HPC staff</li> </ul> </li> </ul>

## i. Eligibility

### Test1

❖ I can be granted an LSU HPC or LONI account if:

- a) I am using HPC resource for my research, the account will be sponsored by my advisor (PI)
- b) I am attending HPC training sessions, the account will be sponsored by the HPC staff
- c) I am taking a class that requires using HPC resource, the account will be sponsored by the course instructor
- d) a and b
- e) a and c
- f) All of the above

## i. Eligibility

### Test1

❖ I can be granted an LSU HPC or LONI account if:

- a) I am using HPC resource for my research, the account will be sponsored by my advisor (PI)
- b) I am attending HPC training sessions, the account will be sponsored by the HPC staff
- c) I am taking a class that requires using HPC resource, the account will be sponsored by the course instructor
- d) a and b
- e) a and c
- f) All of the above

## i. Eligibility

### Test2

#### ❖ Who may be eligible for LSU HPC accounts? (Choose all that apply)

- a) Alice, a professor in Europe, who collaborates with Professor X @ LSU Baton Rouge campus and wishes to run simulations
- b) Bob, recently graduated from LSU and moved to New York for a postdoc position, but is still working with his PhD advisor Professor Y @ LSU Baton Rouge campus to finish their unfinished research
- c) Charlie, a current undergraduate student @ LSU Baton Rouge campus, who is taking an online Machine Learning course given by Professor Z @ Stanford, and needs practice on a GPU-enabled HPC system



## i. Eligibility

### Test2

#### ❖ Who may be eligible for LSU HPC accounts? (Choose all that apply)

- a) Alice, a professor in Europe, who collaborates with Professor X @ LSU Baton Rouge campus and wishes to run simulations
- b) Bob, recently graduated from LSU and moved to New York for a postdoc position, but is still working with his PhD advisor Professor Y @ LSU Baton Rouge campus to finish their unfinished research
- c) Charlie, a current undergraduate student @ LSU Baton Rouge campus, who is taking an online Machine Learning course given by Professor Z @ Stanford, and needs practice on a GPU-enabled HPC system

## ii. How to apply

	LSU HPC	LONI
Portal	<a href="https://accounts.hpc.lsu.edu/login_request.php">https://accounts.hpc.lsu.edu/login_request.php</a>	<a href="https://allocations.loni.org/login_request.php">https://allocations.loni.org/login_request.php</a>

## ii. How to apply

	LSU HPC	LONI
Portal	<a href="https://accounts.hpc.lsu.edu/login_request.php">https://accounts.hpc.lsu.edu/login_request.php</a>	<a href="https://allocations.loni.org/login_request.php">https://allocations.loni.org/login_request.php</a>

## ii. How to apply

	LSU HPC	LONI
Portal	<a href="https://accounts.hpc.lsu.edu/login_request.php">https://accounts.hpc.lsu.edu/login_request.php</a>	<a href="https://allocations.loni.org/login_request.php">https://allocations.loni.org/login_request.php</a>
Steps	<p>a) Enter your <b>institutional email</b> and submit</p> <p>b) Check email and open the link (valid for 24 hrs)</p> <p>c) Fill the form (In <b>Contact/Collaborator</b>, enter your <b>account sponsor</b>'s full name) and submit</p> <p>d) You <b>will receive a notification</b> when your account is activated once we have verified your credentials</p> <ul style="list-style-type: none"><li>• Be patient. Do not reset your password if you cannot log in yet.</li></ul>	

## iii. Manage your account

	LSU HPC	LONI
Portal	<a href="https://accounts.hpc.lsu.edu">https://accounts.hpc.lsu.edu</a>	<a href="https://allocations.loni.org">https://allocations.loni.org</a>

## iii. Manage your account

	LSU HPC	LONI
Portal	<a href="https://accounts.hpc.lsu.edu">https://accounts.hpc.lsu.edu</a>	<a href="https://allocations.loni.org">https://allocations.loni.org</a>
Things to do	<ul style="list-style-type: none"><li>• Change personal information, password, ...</li><li>• Change <b>default shell</b> (bash / tcsh / ksh / csh / sh)</li><li>• Request / manage / check allocation</li><li>• Request / manage / check storage</li><li>• ...</li></ul>	

## iv. Reset password

	LSU HPC	LONI
Portal	<a href="https://accounts.hpc.lsu.edu/user_reset.php">https://accounts.hpc.lsu.edu/user_reset.php</a>	<a href="https://allocations.loni.org/user_reset.php">https://allocations.loni.org/user_reset.php</a>

## iv. Reset password

	LSU HPC	LONI
Portal	<a href="https://accounts.hpc.lsu.edu/user_reset.php">https://accounts.hpc.lsu.edu/user_reset.php</a>	<a href="https://allocations.loni.org/user_reset.php">https://allocations.loni.org/user_reset.php</a>
Steps	<p>a) Enter your registered email and submit</p> <p>b) Check email and open the link (valid for 24 hrs)</p> <p>c) Enter your new password and submit</p> <p>d) You will receive a confirmation email once your new password is approved by our staff</p> <p><b>** IMPORTANT **</b></p> <ul style="list-style-type: none"><li>Your new password is <b>NOT</b> available right away (wait until you receive confirmation of approval)</li><li>Do <b>NOT</b> submit multiple times</li></ul>	



## iv. Reset password

### Case study

- **User:**  
“I have been trying to access my accounts on QB2 via an SSH client, but the connection won't go through. I reset my passwords this weekend and the terminals keep giving me a ‘Password Authentication Failed’ error message.....”
- **User Services:**  
“When you send a password reset request, it has to be manually processed for security reason before your new password becomes available.”

## iv. Reset password

### Password security

- Passwords should be changed as soon as your account is activated for added security.
- Password must be at least 12 and at most 32 characters long, must contain **3 of the 4 classes** of characters
  - Lowercase letters
  - Uppercase letters
  - Digits
  - Special characters (punctuation, spaces, etc.)
- Do not use a word or phrase from a dictionary
- Do not use a word that can be obviously tied to the user (e.g., your name, user name, etc.)
- **Do NOT share your password to others, including your advisor!!!!**

- **HPC User Environment 1**

1. Intro to HPC
  - 1) Why HPC?
  - 2) What is HPC?
  - 3) Our HPC
2. **Getting started**
  - 1) Accounts
  - 2) Allocation
3. Intro the cluster
  - 1) Getting connected
  - 2) File system
4. Software environment
  - 1) Preinstalled (modules)
  - 2) User installation



## i. What is **allocation**?

- A deposit of **service units (SU)** that users will be charged from to run jobs on our cluster
  - 1 SU = 1 core-hour
  - Example:
    - My allocation: 50,000 SU
    - Running a job: 24 core \* 10 hours = 240 SU
    - Balance: 49,760 SU
  - Cannot run jobs after exhausted
- All LSU HPC & LONI clusters requires allocation to run jobs
- **Free** to users
- But not worthless! (**1 SU ≈ \$0.1**)

## ii. Eligibility

You are a ...	To get allocation ...

## ii. Eligibility

You are a ...	To get allocation ...
Account sponsor / PI*	Submit a request

\* Full-time faculty & certain research staff @ LSU / LONI subscribers



## ii. Eligibility

You are a ...	To get allocation ...
Account sponsor / PI*	Submit a request
Non-account sponsor / non-PI	Join your sponsor's allocation

\* Full-time faculty & certain research staff @ LSU / LONI subscribers

### iii. Request an allocation (if you are an account sponsor / PI)

	LSU HPC	LONI
Portal	<a href="https://accounts.hpc.lsu.edu/allocations.php">https://accounts.hpc.lsu.edu/allocations.php</a>	<a href="https://allocations.loni.org/allocations.php">https://allocations.loni.org/allocations.php</a>

## iii. Request an allocation (if you are an account sponsor / PI)

	LSU HPC	LONI
Portal	<a href="https://accounts.hpc.lsu.edu/allocations.php">https://accounts.hpc.lsu.edu/allocations.php</a>	<a href="https://allocations.loni.org/allocations.php">https://allocations.loni.org/allocations.php</a>
Steps	a) Log in using your account b) Click on “New Allocation for [Cluster Name]” <ul style="list-style-type: none"><li>• SuperMIC &amp; SuperMike III share allocations</li><li>• QB2 and QB3 share allocations</li><li>• Deep Bayou has separated allocation</li></ul> c) Fill the form and submit d) Your request will be reviewed, and you will be notified if your allocation is approved	

## iii. Request an allocation (if you are an account sponsor / PI)

### Allocation types

Type	Size [SU]	Can be requested...	Decisions made on...	Activated on...	Limited to...

## iii. Request an allocation (if you are an account sponsor / PI)

### Allocation types

Type	Size [SU]	Can be requested...	Decisions made on...	Activated on...	Limited to...
Startup	150,000	Any time	Following request	Jan 1 Apr 1 Jul 1 Oct 1	2 active / PI

## iii. Request an allocation (if you are an account sponsor / PI)

### Allocation types

Type	Size [SU]	Can be requested...	Decisions made on...	Activated on...	Limited to...
Startup	150,000	Any time	Following request	Jan 1 Apr 1 Jul 1 Oct 1	2 active / PI
Research	> 150,000	➤ 1 month before decision date (allocation starts)	Jan 1 Apr 1 Jul 1 Oct 1		<b>[ LSU HPC ]</b> 5,000,000 SU / allocation 12,000,000 SU / PI  <b>[ LONI ]</b> 8,000,000 SU / allocation 16,000,000 SU / PI

[1] <https://www.hpc.lsu.edu/users/hpcpolicy.php#allocations>

[2] <http://hpc.loni.org/users/lonipolicy.php#system-allocation>

iii. Request an allocation (if you are an account sponsor / PI) from LSU HPC

## Allocation types

Type	Size [SU]	Proposal				
		Technical merit	Software characteristics	Previous impact and outcome	External funding or LSU demand	# of pages
Startup	150,000	(Not required)				
Research	A >150,000 and ≤300,000	Required	Required	Optional	Optional	4
	B >300,000 and ≤1,000,000	Required	Required	Required	Optional	5
	C >1,000,000	Required	Required	Required	Required	6

[1] <https://www.hpc.lsu.edu/users/hpcpolicy.php#allocations>

iii. Request an allocation (if you are an account sponsor / PI) from LONI HPC

## Allocation types

Type	Size [SU]	Proposal				
		Problem Statement	Background	Methodology	Research Plan	Requirements Analysis
Startup	150,000	(Not required)				
Large	>150,000 and ≤8,000,000	Please refer to: <a href="http://hpc.loni.org/users/lonipolicy.php#system-allocation">http://hpc.loni.org/users/lonipolicy.php#system-allocation</a>				



## iv. Join an allocation (if you are not an account sponsor / PI)

	LSU HPC	LONI
Portal	<a href="https://accounts.hpc.lsu.edu/allocations.php">https://accounts.hpc.lsu.edu/allocations.php</a>	<a href="https://allocations.loni.org/allocations.php">https://allocations.loni.org/allocations.php</a>

## iv. Join an allocation (if you are not an account sponsor / PI)

	LSU HPC	LONI
Portal	<a href="https://accounts.hpc.lsu.edu/allocations.php">https://accounts.hpc.lsu.edu/allocations.php</a>	<a href="https://allocations.loni.org/allocations.php">https://allocations.loni.org/allocations.php</a>
Steps	<p><b>[ Method 1: Join by request ]</b></p> <ul style="list-style-type: none"><li>a) Log in using your account</li><li>b) Click on “Join allocation”</li><li>c) Search for your account sponsor / PI, and click "Join Projects"</li><li>d) Find the desired allocation you wish to join, click “Join”</li><li>e) Your account sponsor / PI will receive an email notification and approve your request</li></ul> <p><b>[ Method 2: Ask your PI to add you ]</b></p> <ul style="list-style-type: none"><li>a) Ask your PI to log in using his/her account</li><li>b) Click on “Manage memberships”</li><li>c) Find the desired allocation, click “Edit -&gt; Add a User”</li><li>d) Search for your account, click “Add to [Allocation name]”</li></ul>	

\* HPC staff **CANNOT** add you to allocations! Must be approved by your PI!

## iv. Join an allocation (if you are not an account sponsor / PI)

### Case study

- **User:**  
“Hi, my PI recently applied for an allocation on SuperMIC and was approved (see forwarded email below). However, I do not see that this allocation is available for my use in <https://accounts.hpc.lsu.edu/balances.php> . When will I be able to access the allocation?”
- **User Services:**  
“You should either request to join your PI’s allocation through the user portal, or ask your PI to add you to the allocation”

- **Test**

- ❖ **What are the TWO things required to run jobs on our clusters?**

- a) An active myLSU account
- b) An active LSU HPC / LONI account
- c) An active LSU HPC / LONI allocation
- d) A valid payment method (credit card / bank account / check / cash ...) to pay for the services

- **Test**

- ❖ **What are the TWO things required to run jobs on our clusters?**

- a) An active myLSU account
- b) An active LSU HPC / LONI account
- c) An active LSU HPC / LONI allocation
- d) A valid payment method (credit card / bank account / check / cash ...) to pay for the services

- Login to one of the user portals (LSU HPC or LONI) with your HPC username and password. Update your email and phone number (for practice).
  - LSU HPC: <https://accounts.hpc.lsu.edu>
  - LONI: <https://allocations.loni.org>
- Download MobaXterm (if you are Windows user)
- Review commands in Linux and the vim editor

## Cheat sheet of Commands in Linux

history	Command history
mkdir	Make a folder
ls	List a folder -a List all files including hidden -l Shows files with a long listing format
cd	Change directory
pwd	Show current directory
cp	Copy
rm	Remove files (CAREFUL!)
Up arrow (↑)	Move back in history
Tab	Fill in unique file name
Tab Tab	Press tab twice, show all available file names

## Cheat sheet of vim editor

- vi (name of file)
- Commands in VI
  - i enter insert mode (-- INSERT -- shows in the bottom left corner)
  - esc exits insert mode, back to the command mode
    - dd -> deletes line
    - u -> Undo
    - Shift Z shift Z or :wq -> saves and exits VI
    - :q! -> exit without saving
    - :(some number) -> moves through file to row #
    - /(indicator) -> search
      - Use N to find Next
    - [ (page up) ] (page down)
- NO CAPS (for example :q! is not :Q!)



- **HPC User Environment 1**

1. Intro to HPC
  - 1) Why HPC?
  - 2) What is HPC?
  - 3) Our HPC
2. Getting started
  - 1) Accounts
  - 2) Allocation
3. **Intro the cluster**
  - 1) **Getting connected**
  - 2) File system
4. Software environment
  - 1) Preinstalled (modules)
  - 2) User installation

# 1) Getting connected

## i. General architecture

Term	Definition
<b>Cluster</b>	A set of connected computer nodes that work together. (E.g., QB2)
<b>Node</b>	A single, named host machine in the cluster. (E.g., qb010)
<b>Core</b>	The basic computation unit in a processor. (E.g. , QB2 has two 10-core processors → 20 cores)
<b>Job</b>	A user's request to use a certain amount of resources for a certain amount of time on cluster for his/her work.

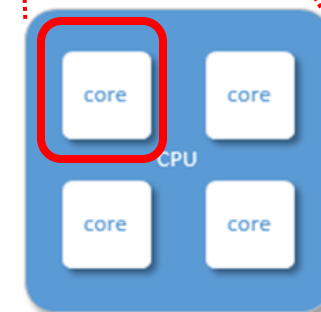
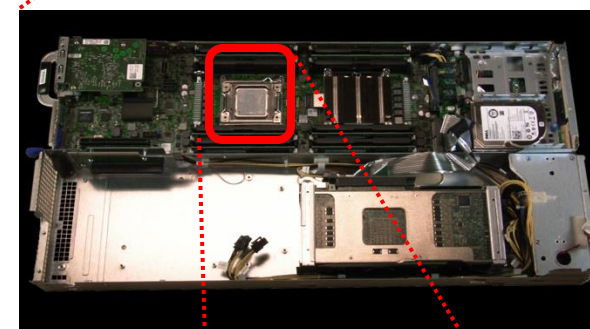
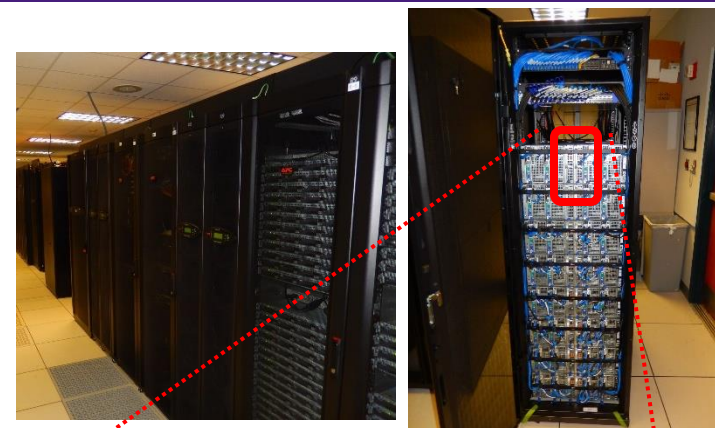

## i. General architecture

- Multiple compute nodes
- Multiple users
- Each user may have multiple jobs running simultaneously

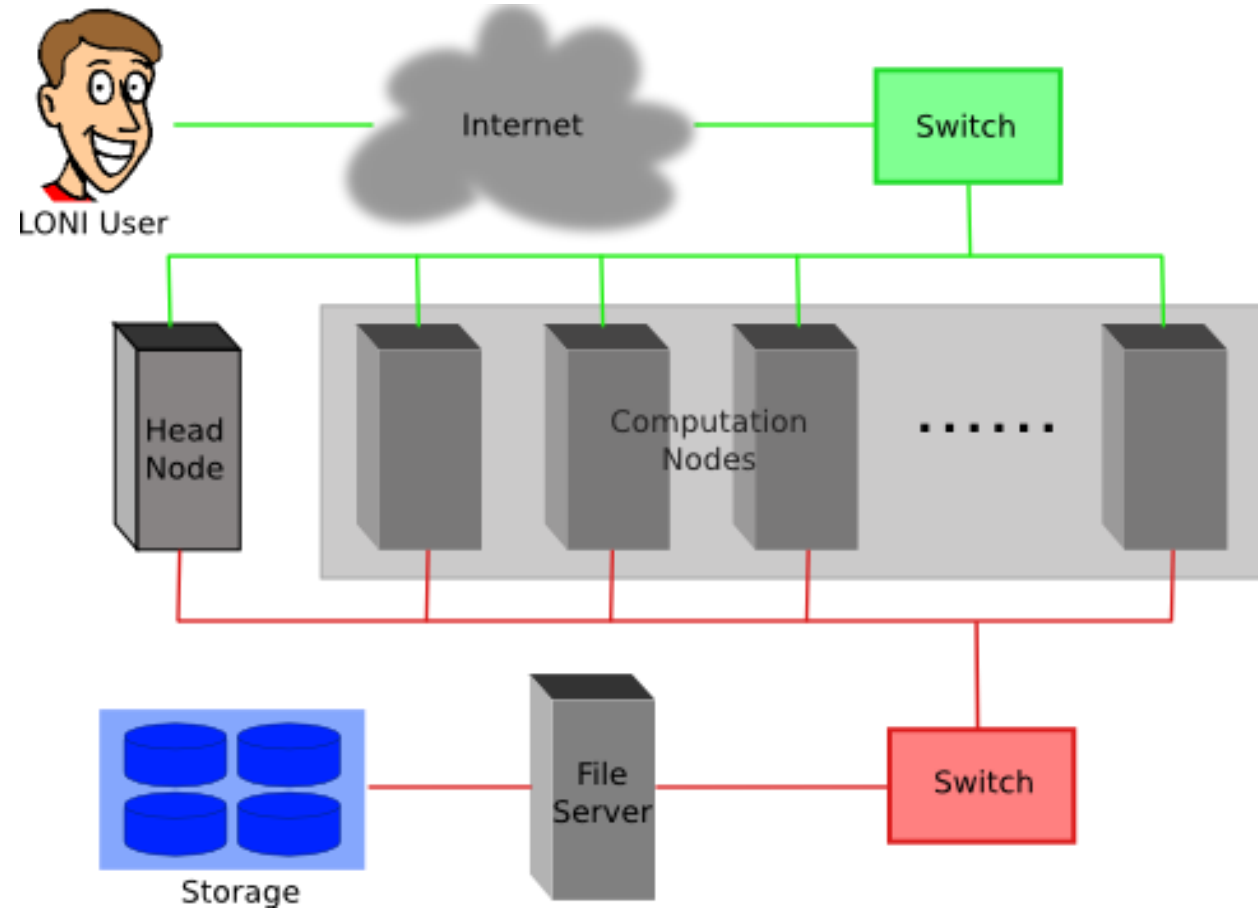

# 1) Getting connected

## i. General architecture

- Multiple compute nodes
- Multiple users
- Each user may have multiple jobs running simultaneously

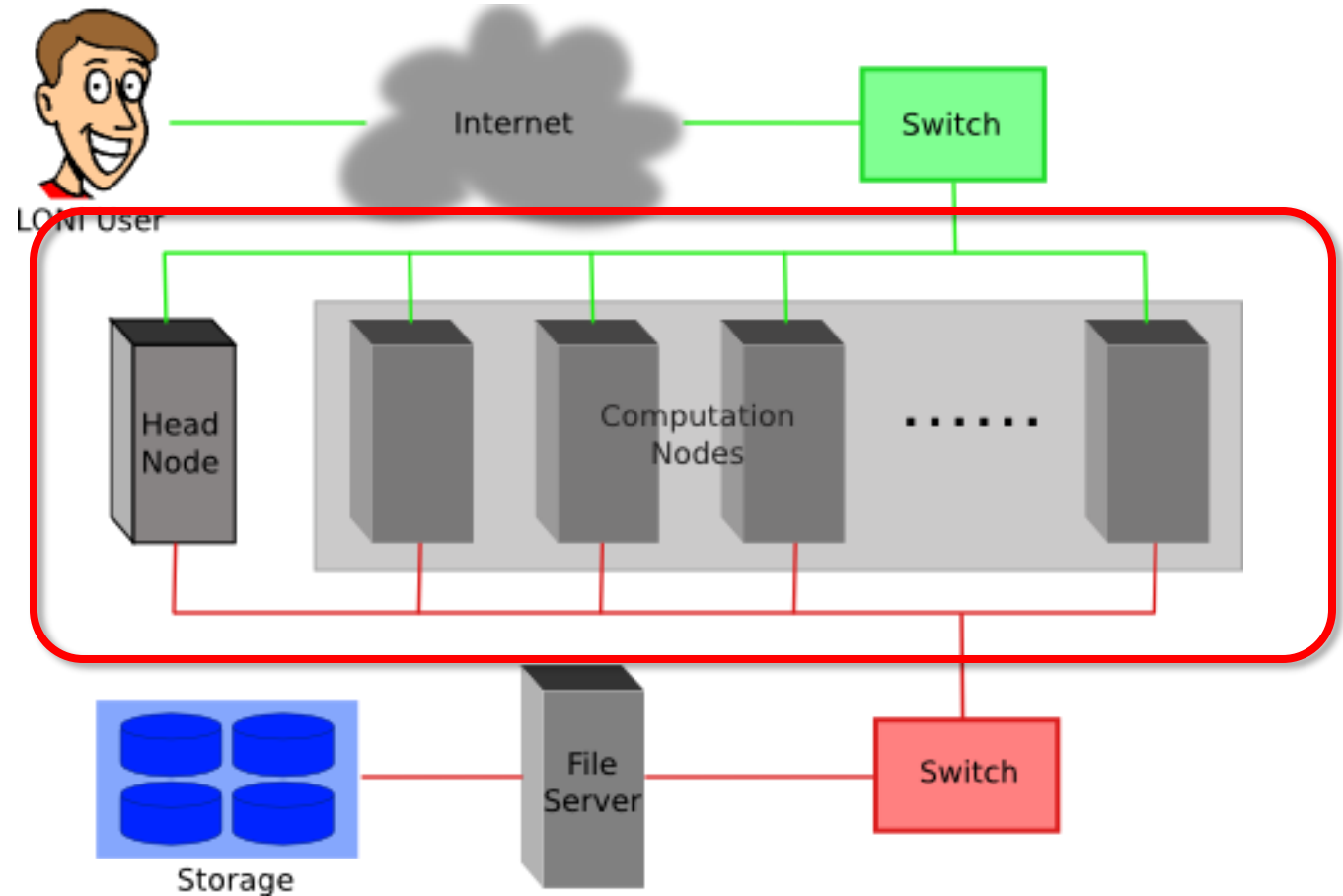

## i. General architecture

- Multiple compute nodes
- Multiple users
- Each user may have multiple jobs running simultaneously

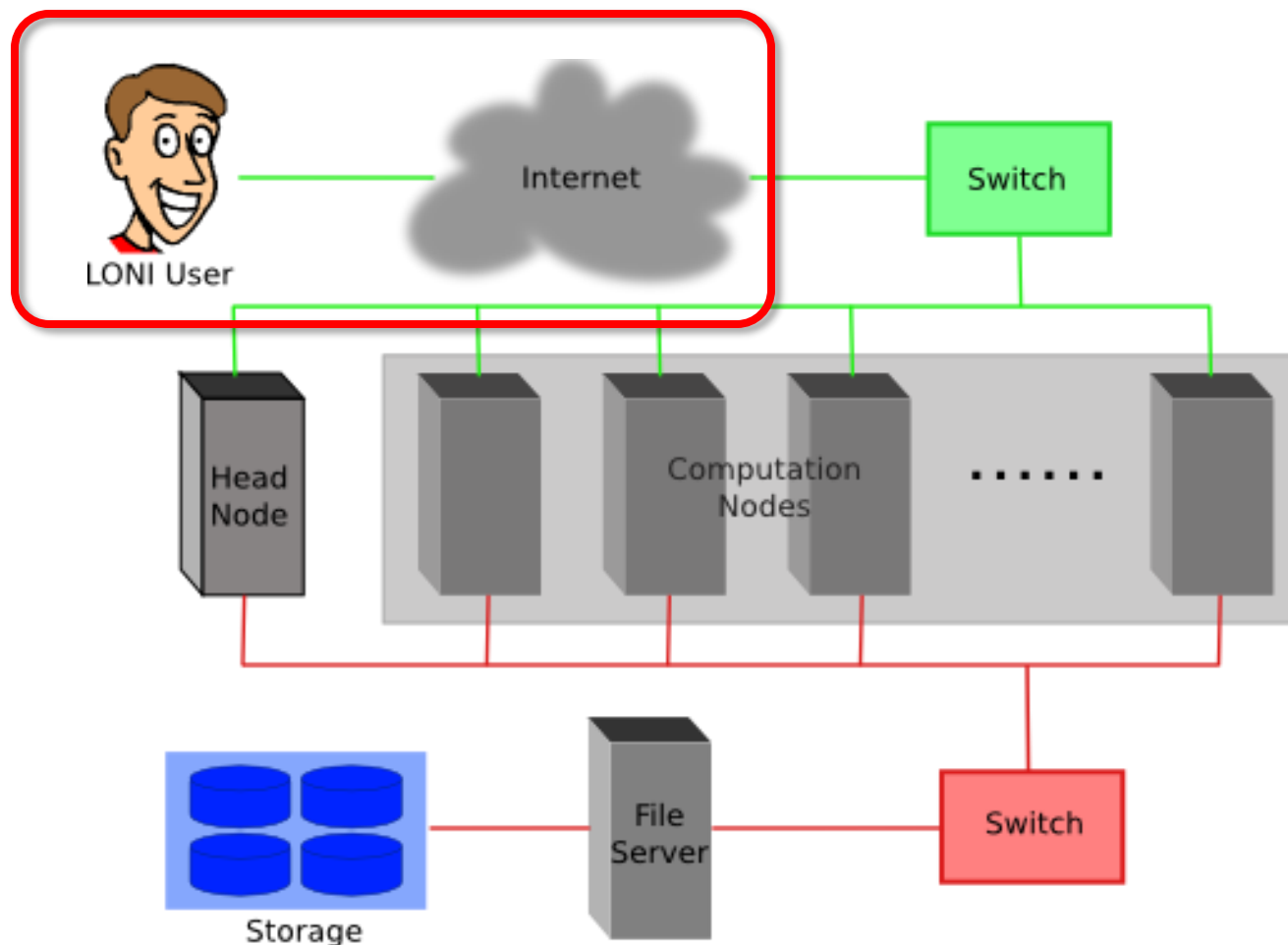

# 1) Getting connected

## i. General architecture

- Multiple compute nodes
- Multiple users
- Each user may have multiple jobs running simultaneously

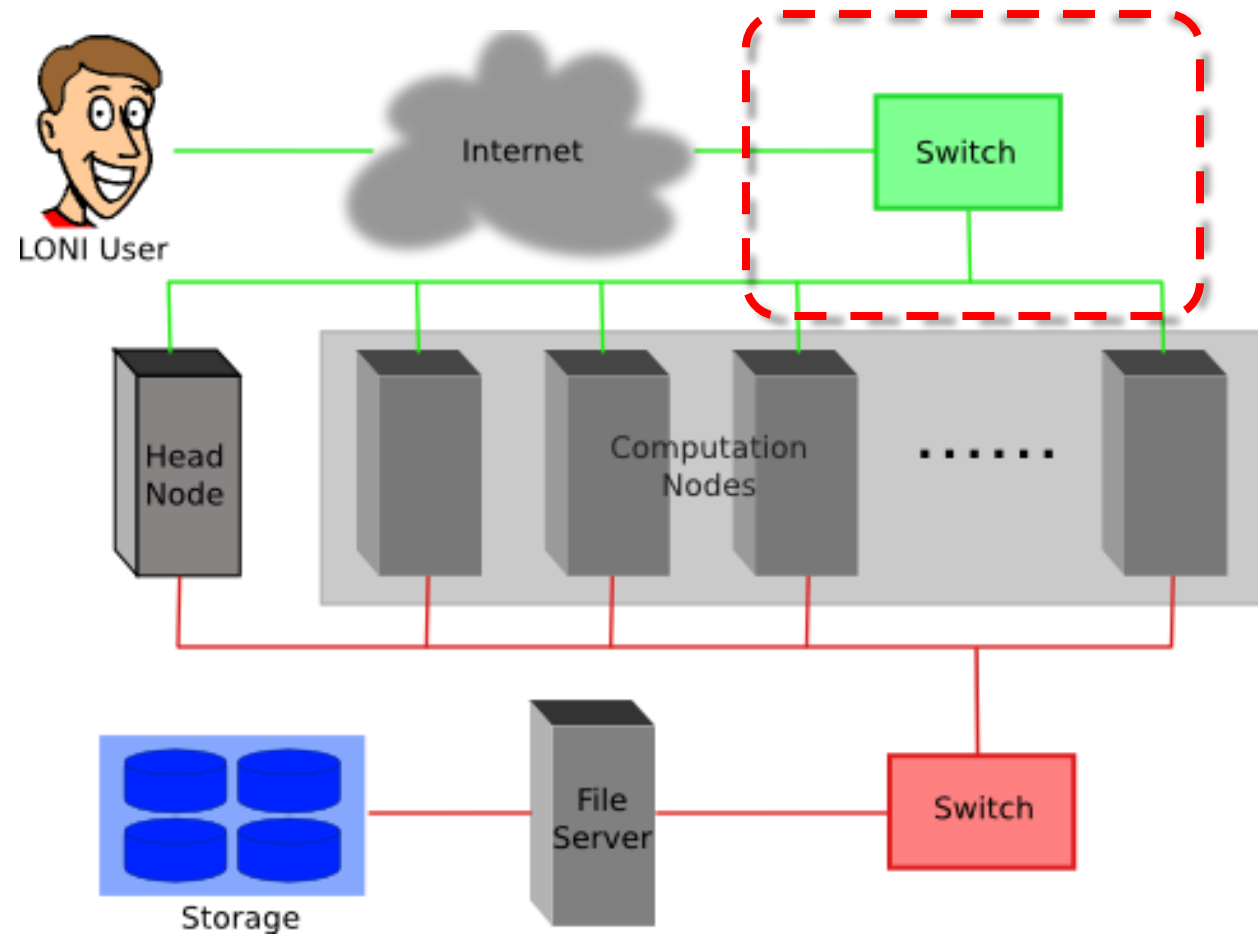

## i. General architecture

- Multiple compute nodes
- Multiple users
- Each user may have multiple jobs running simultaneously

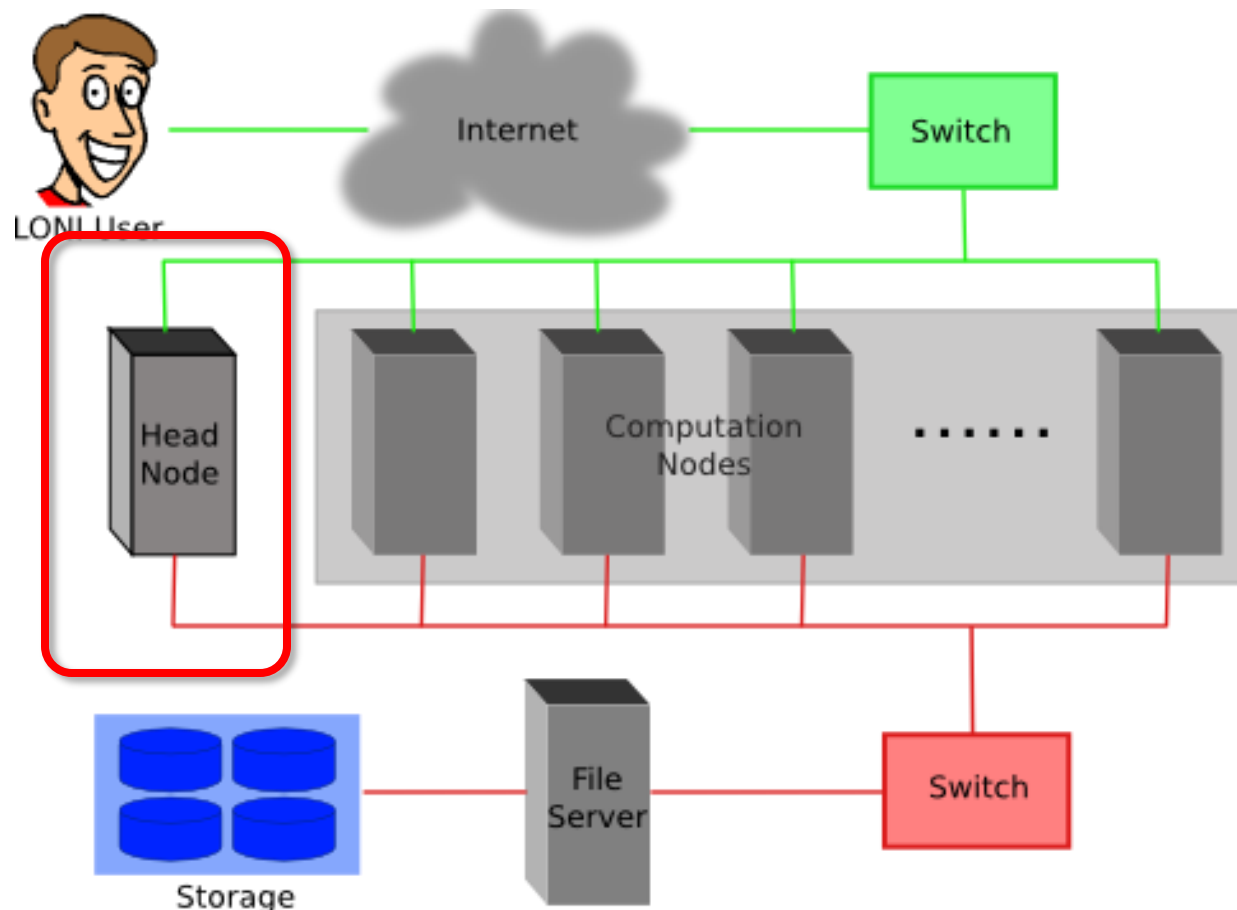

## i. General architecture

- Multiple compute nodes
- Multiple users
- Each user may have multiple jobs running simultaneously

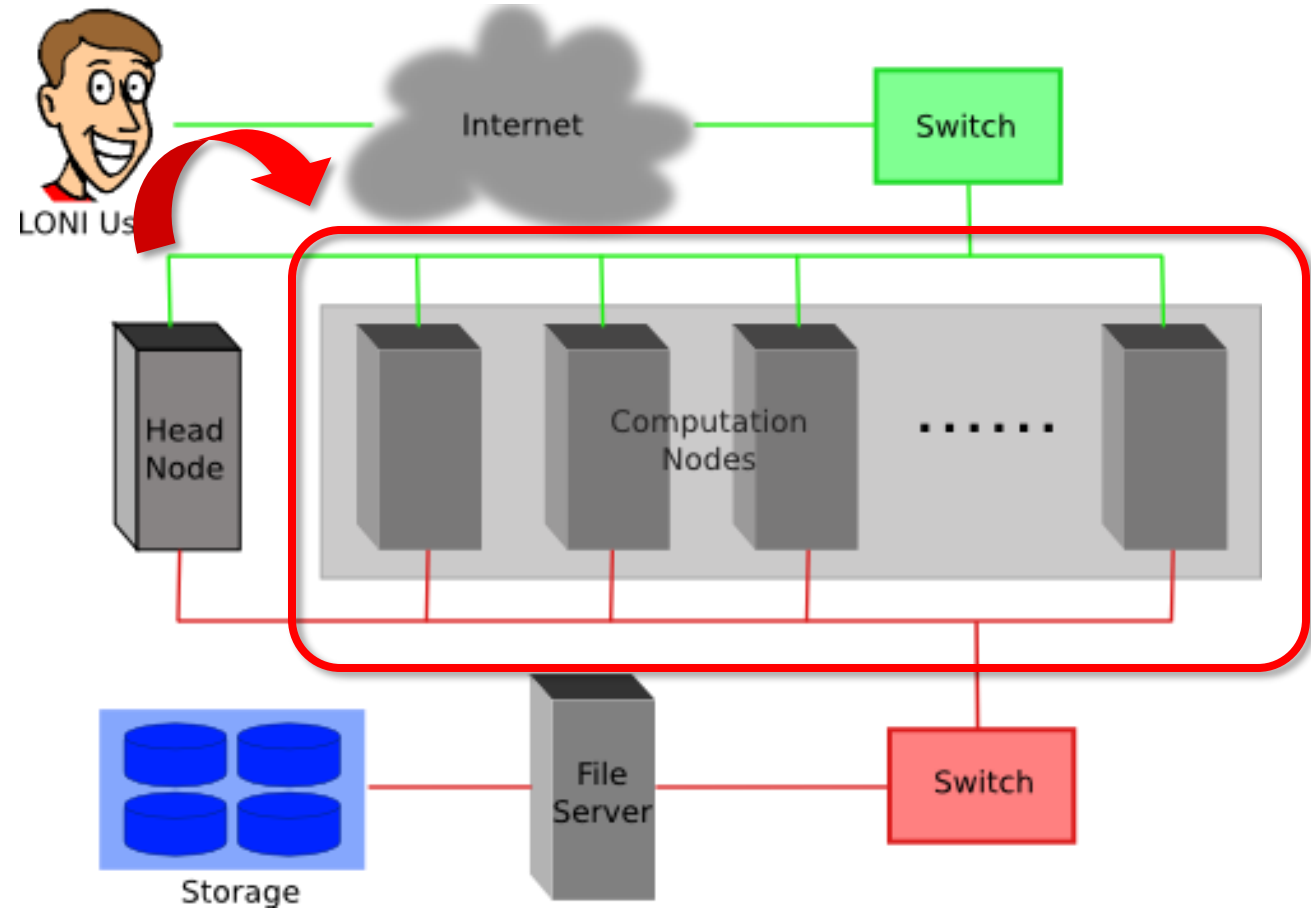



# 1) Getting connected

## i. General architecture

- Multiple compute nodes
- Multiple users
- Each user may have multiple jobs running simultaneously



[user@mike1 ~]\$ python my.fancy.super.large.job.py

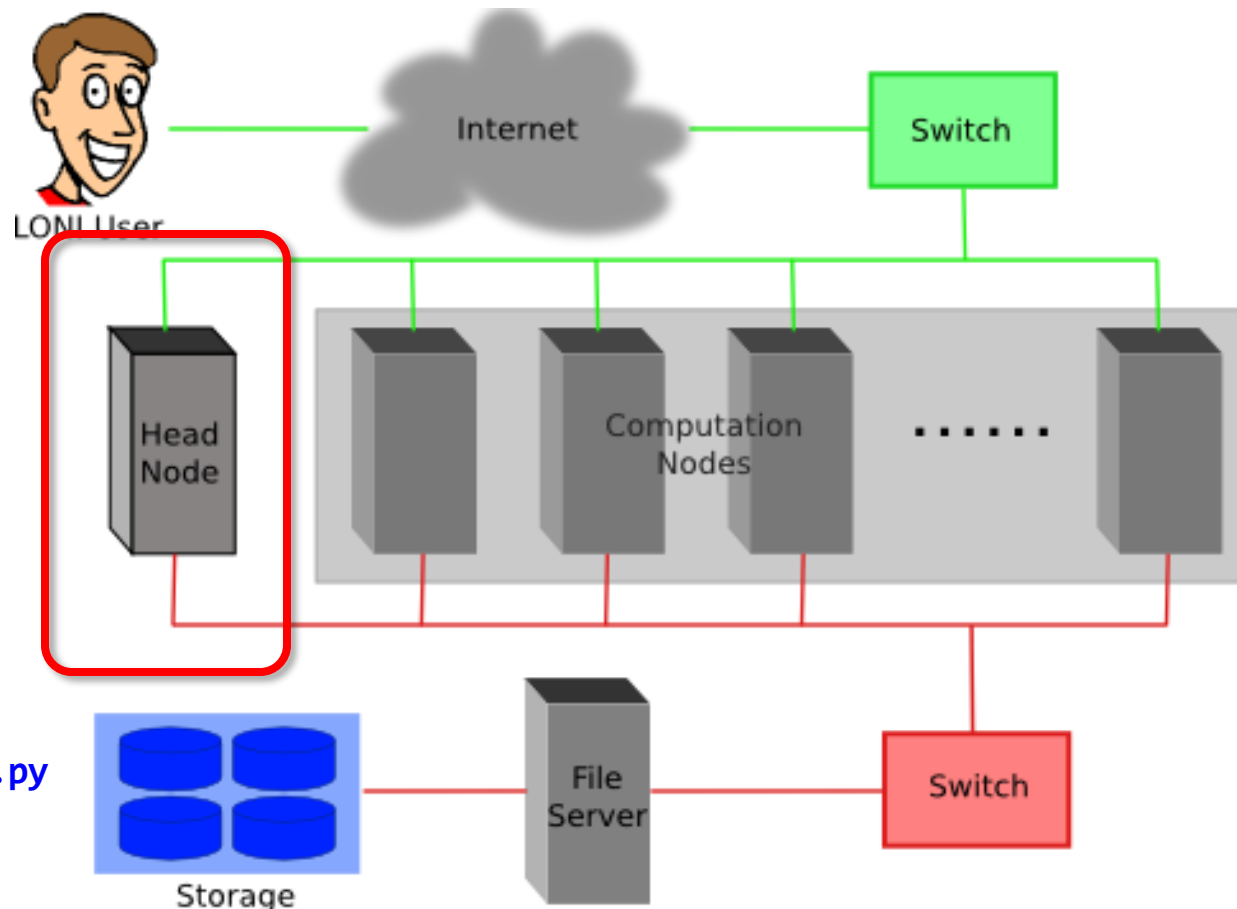

## ii. Logging in

### Secure Shell (SSH)

## ii. Logging in

### Secure Shell (SSH)

Your OS ...	Tool you need ...
Linux / Mac	Terminal
Windows	<b>MobaXterm</b> Putty Or other ssh client software
A web browser*	Open OnDemand (OOD) <a href="https://ondemand.smic.hpc.lsu.edu">https://ondemand.smic.hpc.lsu.edu</a> <a href="https://ondemand.mike.hpc.lsu.edu">https://ondemand.mike.hpc.lsu.edu</a>

\* Must from LSU Baton Rouge campus (or via VPN off-campus)

## ii. Logging in

### Secure Shell (SSH)

Cluster		Remote Host Address
LSU HPC	SMIC	<code>smic.hpc.lsu.edu</code>
	Deep Bayou	<code>db1.hpc.lsu.edu</code>
	SuperMike III	<code>mike.hpc.lsu.edu</code>
LONI	QB-2	<code>qb.loni.org</code>
	QB-3	<code>qbc.loni.org</code>
	QB-4	<code>qbd.loni.org</code>

## ii. Logging in

```
ssh -X username @ remote host address
```

# 1) Getting connected

## ii. Logging in

### a) Linux / Mac

```
fchen14@feng-thinkpad:~$ ssh fchen14@mike.hpc.lsu.edu
fchen14@mike.hpc.lsu.edu's password:
Last login: Mon Aug 18 11:26:16 2014 from fchen14-4.lsu.edu
#####
Send questions and comments to the email ticket system at sys-help@loni.org.
#####

SuperMike-II at LSU (Open for general use)

1-Dec-2012

SuperMike-II is a 146 TFlops Peak Performance, 440 node, 16 processor Red Hat
Enterprise Linux 6 cluster from Dell with 2.6 GHz Intel Xeon 64-bit processors
and 32 GB RAM per node. GPUs and additional memory are available on some nodes.
This cluster is for authorized users of the LSU community. Access is restricted
to those who meet the criteria as stated on our website.

1-Feb-2013

SuperMike-II is open for general use. Please report problems to our email ticket
system at sys-help@loni.org so that we can address them.

Quotas for the /home volume are enabled at 5 GB. Please do
```

# 1) Getting connected

## ii. Logging in

### b) Windows

- MobaXterm

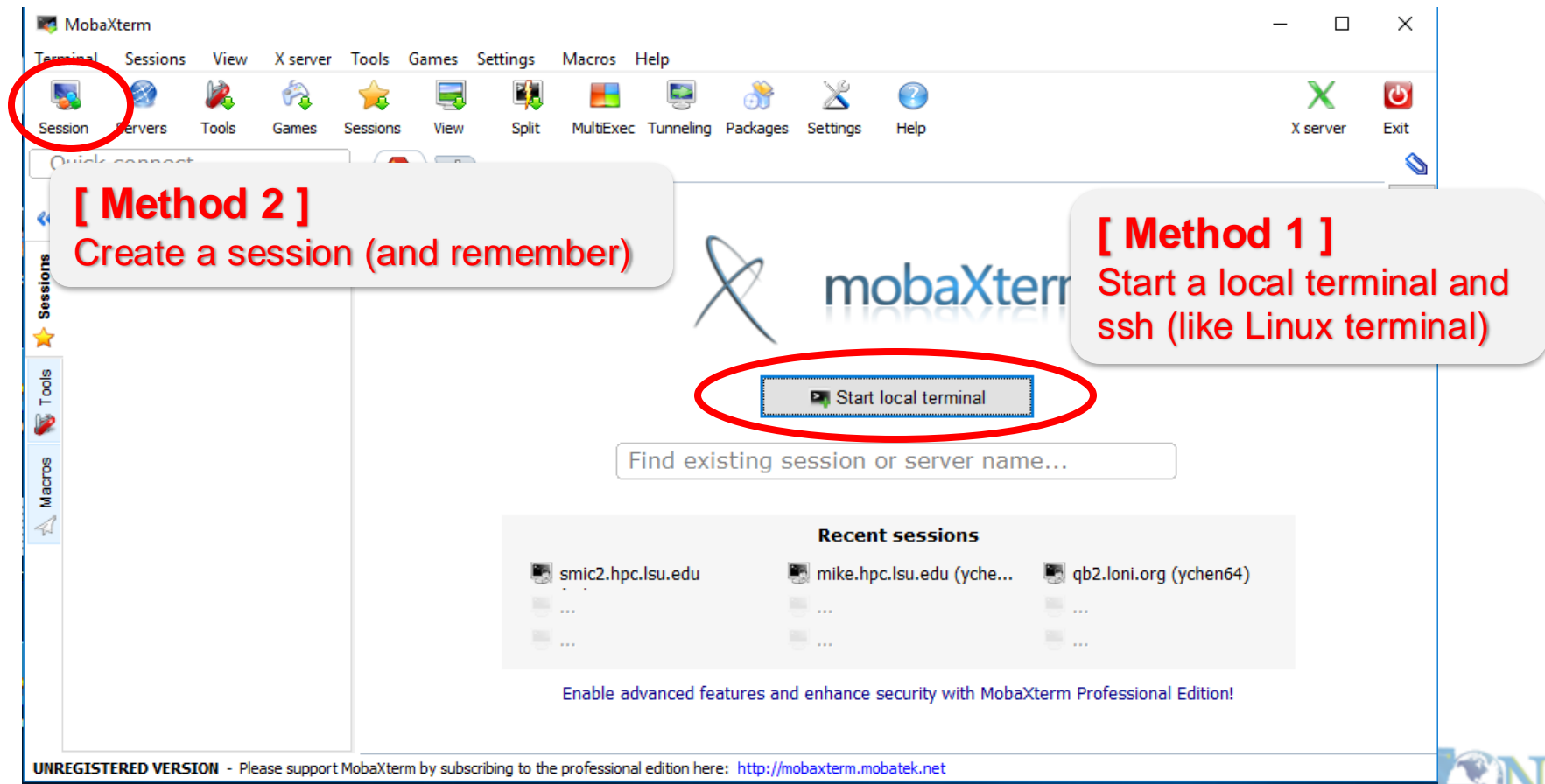

# 1) Getting connected

## ii. Logging in

### b) Windows

- Putty

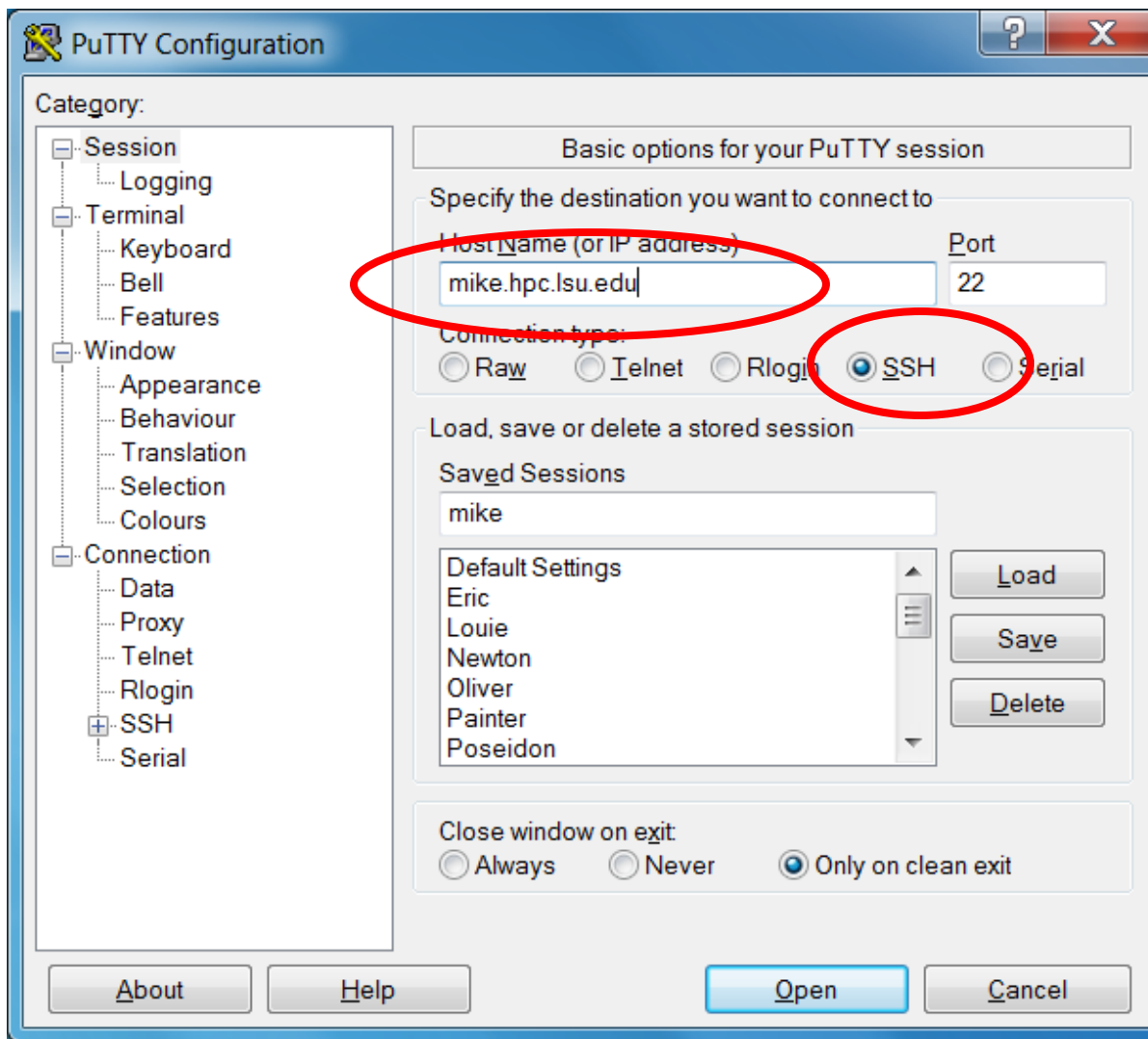



# 1) Getting connected

## ii. Logging in

### b) Windows

- SSH Secure Shell

**NO longer works on our clusters!**

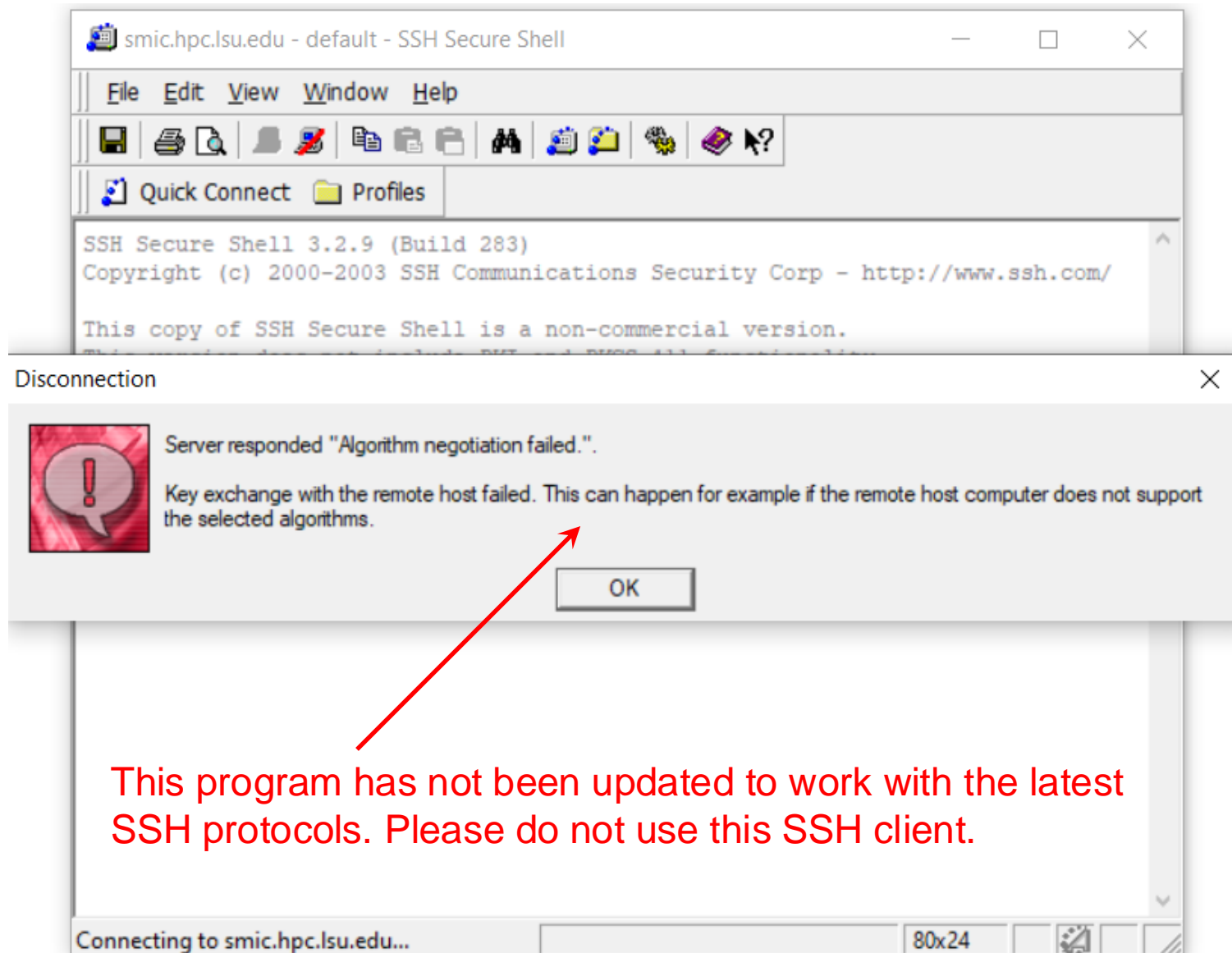

## ii. Logging in

- ❖ Special note: **X11 forwarding**
  - Enables graphic user interface (GUI)

## ii. Logging in

- ❖ Special note: **X11 forwarding**
  - Enables graphic user interface (GUI)

You are using...		To enable X11 forwarding...
Linux (e.g., Ubuntu)		<code>ssh -X username@server.address</code>
Mac		a) Install X server (e.g. XQuartz) b) <code>ssh -X username@server.address</code>
Windows	MobaXterm	<b>Enabled by default</b> (can be disabled in “Advanced SSH Settings”)
	Putty	a) Install X server (e.g. Xming) b) Connection → SSH → X11 → Enable X11 forwarding

- For security considerations, LSU and LONI HPC clusters require multi-factor authentication (MFA).
- **Why Two-Factor Authentication (2FA) is Essential?**
  - Enhanced Security: Adds an extra layer of protection by requiring two forms of verification (something you know and something you have). Even if your password is compromised, your account remains secure.
  - Protection Against Cyber Threats: Helps prevent unauthorized access due to phishing, social engineering, or password theft.
  - Reduces the risk of identity theft and data breaches.
- **Quick and Easy to Use:**
  - Once set up, 2FA verification is fast and straightforward, ensuring minimal disruption to your login process.
  - After successful password and token prompts, subsequent ssh logins within a **12-hour** period will only prompt for a password.

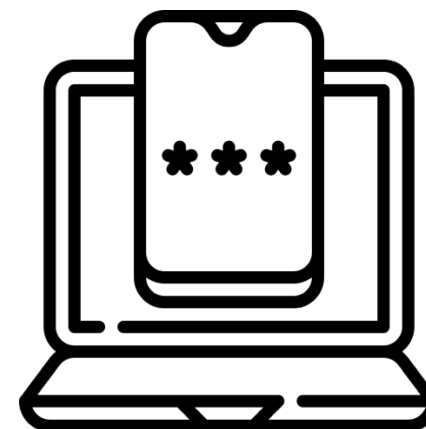

## 1. Install an authenticator on your smartphone

We recommend [Google Authenticator](#), but any Time-based One-Time Password (TOTP) authenticator (e.g. [Microsoft Authenticator](#), [Authy](#) etc.) would do. You can search for these authenticators in the app store for any apps on your phone.

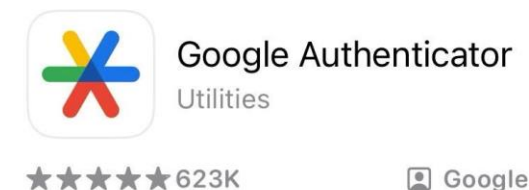

## 2. Log in to the cluster using your credentials: `ssh -X your_username@qbd.loni.org`

You will see a QR code along with some text and a prompt for the one-time token:

3. Open (one time) the authentication app on your phone and scan the QR code.

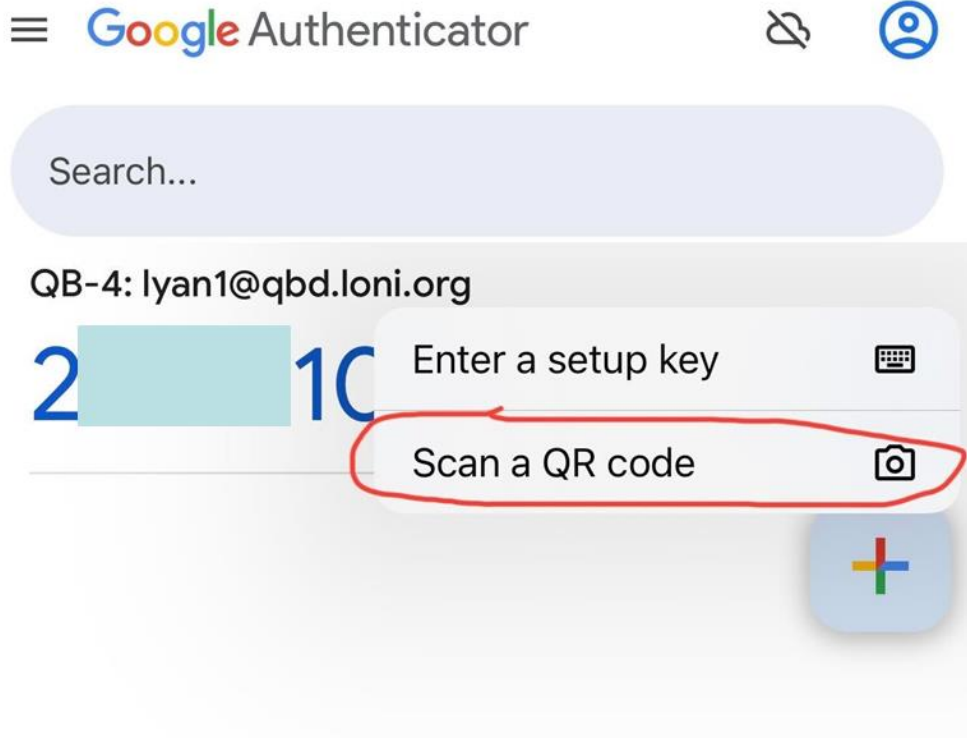

4. Type the 6-digit one-time token at the prompt and press enter.

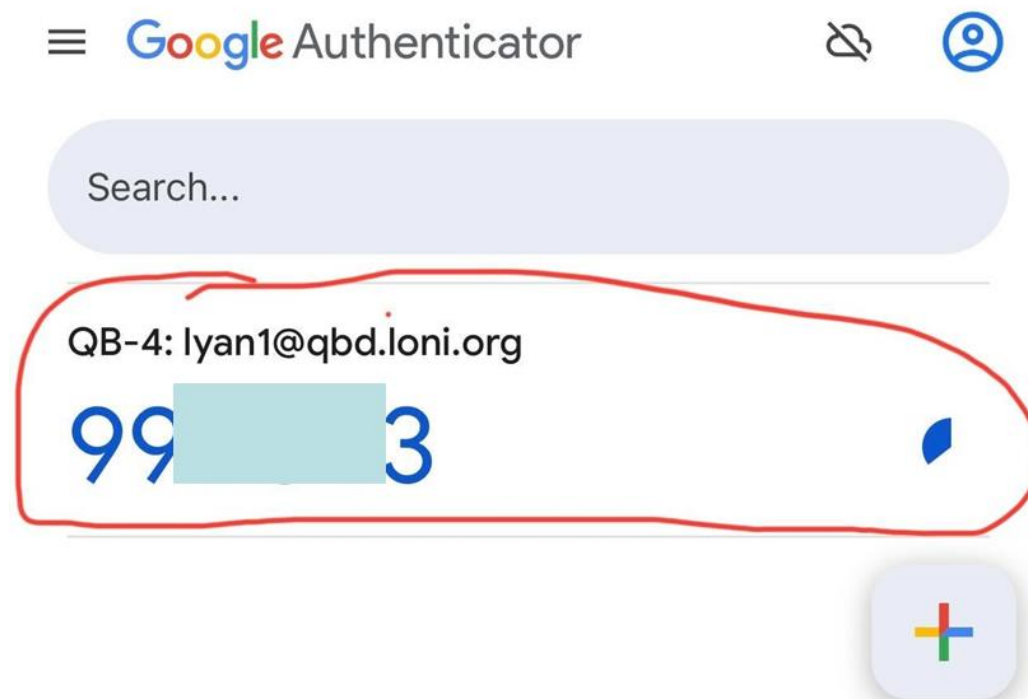

**Note: the token will expire in 30 seconds after being generated. If it expires, simply use the new token.**

**5. Log out and log back in with your ssh client. You should see the token prompt after entering your password.**

**6. Enter the token in your authenticator at the prompt as you did in Step 4.**

- If you log in successfully, no token will be required again for the next 12 hours if you log in from the same IP address. You do not need to type your password everytime.
- In the future, you only need to repeat **Step 5** and **6** to log in.

If you do not have a smartphone or the authenticators do not work on your phone, you can also choose to use desktop applications. [KeepPassXC](#) is an excellent choice, which also provides a browser extension and can be used as a password manager. If you need help setting it up, please contact us at [sys-help@loni.org](mailto:sys-help@loni.org).



# Special note for windows Putty users

- Windows users using PuTTY, the QR code may not display properly with the default settings, making it unscannable using a phone.
- Solution: adjust the "Columns" setting under the "Window" settings from 80 to 160.

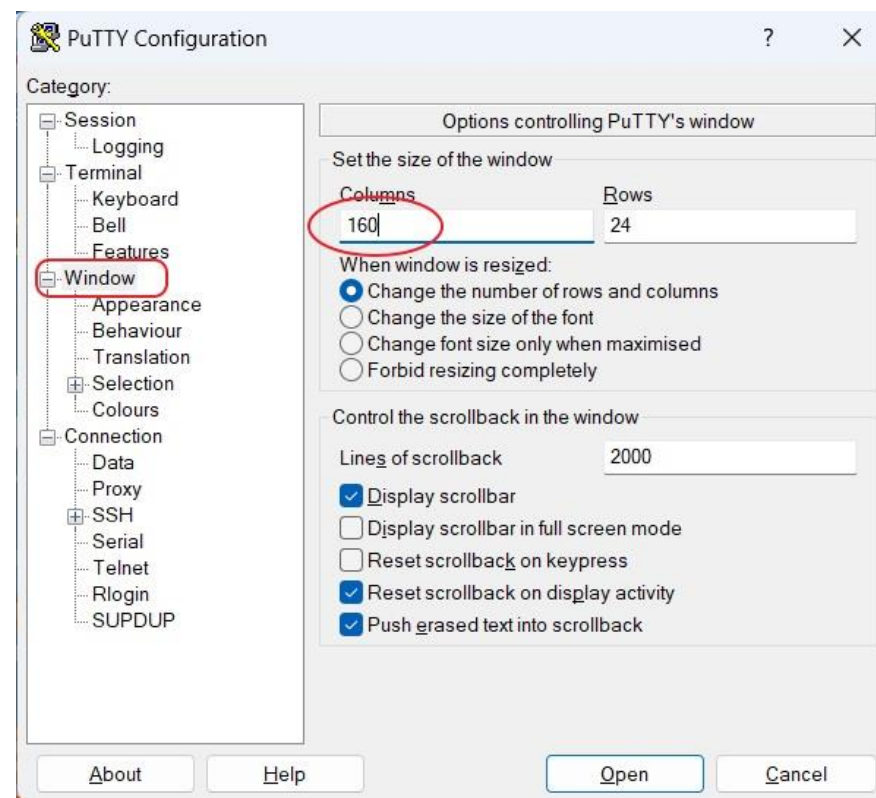
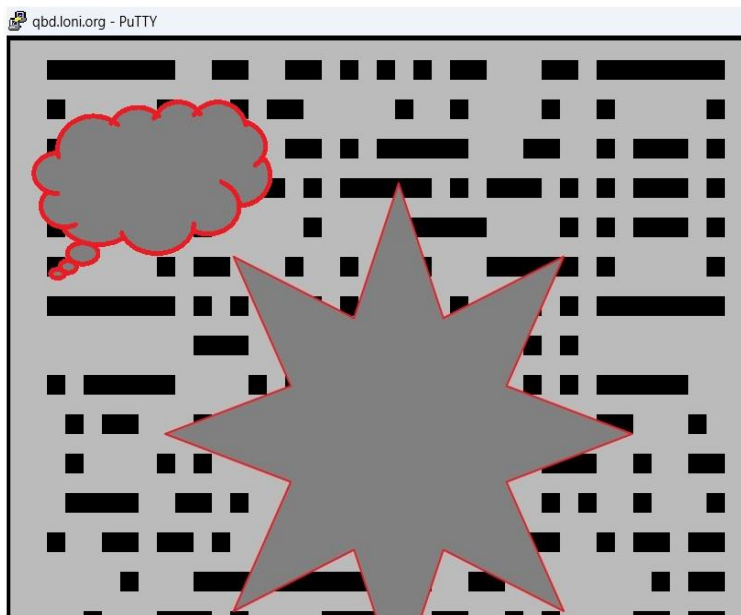

## ii. Logging in

Useful commands	
<code>who</code>	Check who is on the node
<code>balance / showquota</code>	Check allocation balance
<code>history</code>	Command history
<code>mkdir</code>	Make a folder
<code>ls</code>	List a folder -a List all files including hidden -l Shows files with a long listing format
<code>cd</code>	Change directory
<code>pwd</code>	Show current directory
<code>cp</code>	Copy
<code>rm</code>	Remove files (CAREFUL!)
Up arrow (↑)	Move back in history
Tab	Fill in unique file name
Tab Tab	Press tab twice, show all available file names

- **HPC User Environment 1**

1. Intro to HPC
  - 1) Why HPC?
  - 2) What is HPC?
  - 3) Our HPC
2. Getting started
  - 1) Accounts
  - 2) Allocation
3. **Into the cluster**
  - 1) Getting connected
  - 2) **File system**
4. Software environment
  - 1) Preinstalled (modules)
  - 2) User installation

# 2) File system

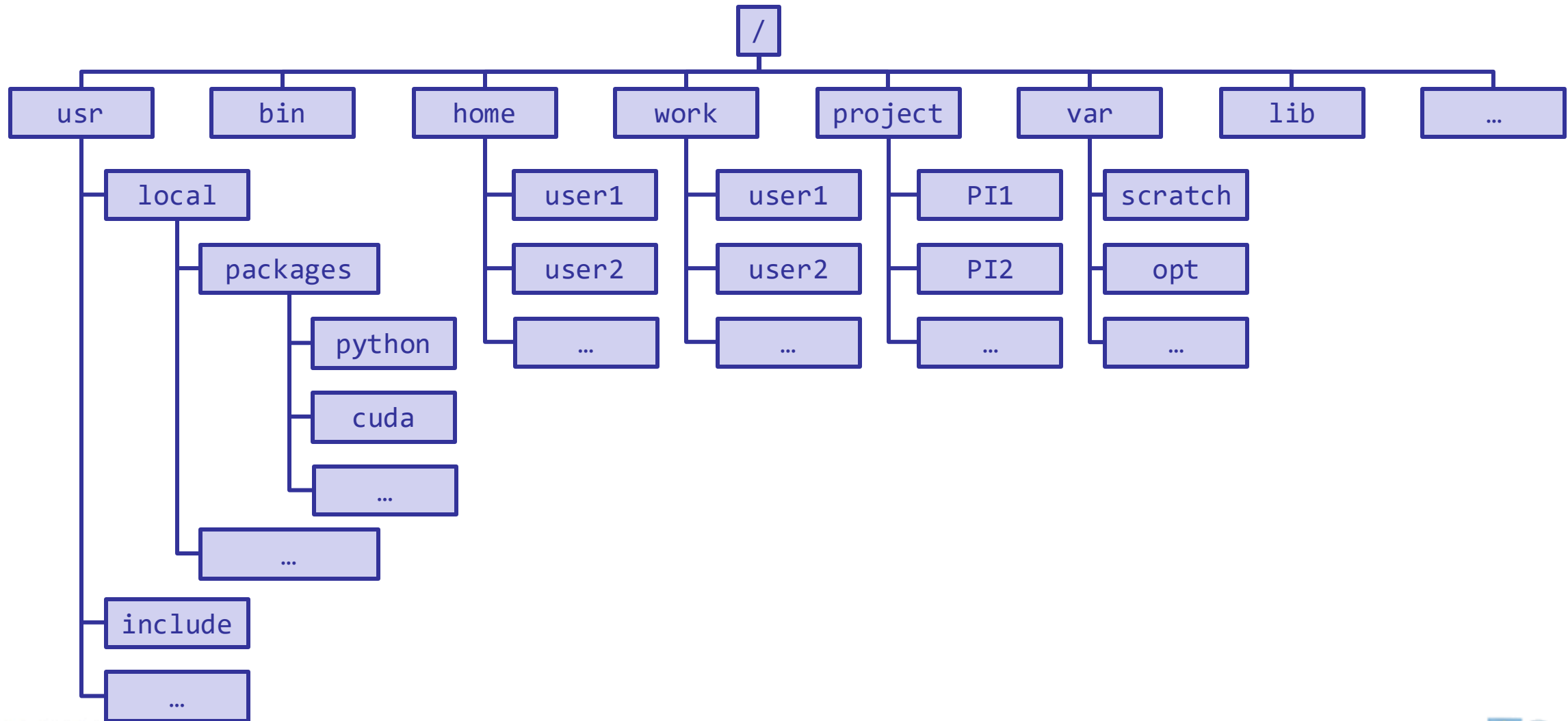

# 2) File system

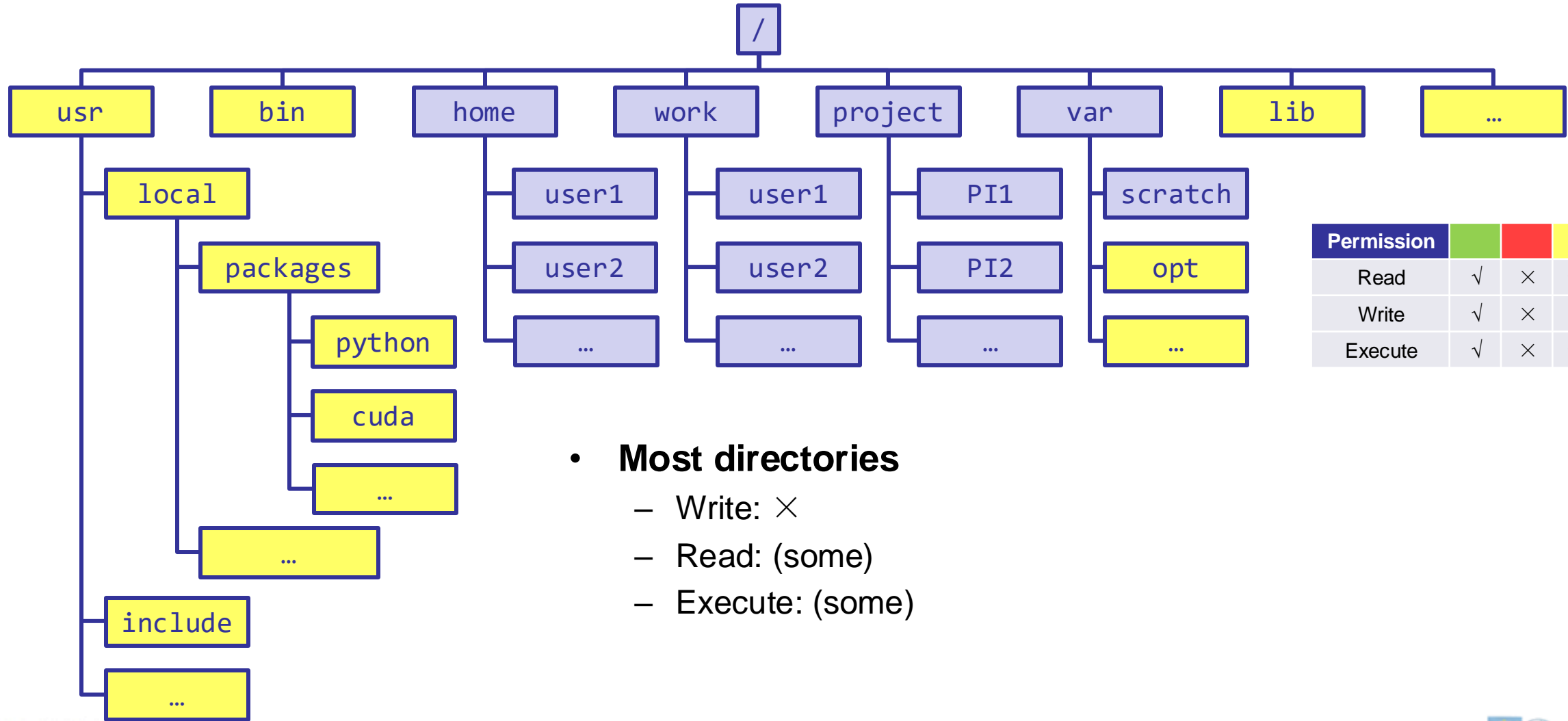

Permission	Green	Red	Yellow
Read	√	×	√*
Write	√	×	×
Execute	√	×	√*

- **Most directories**
  - Write: ×
  - Read: (some)
  - Execute: (some)

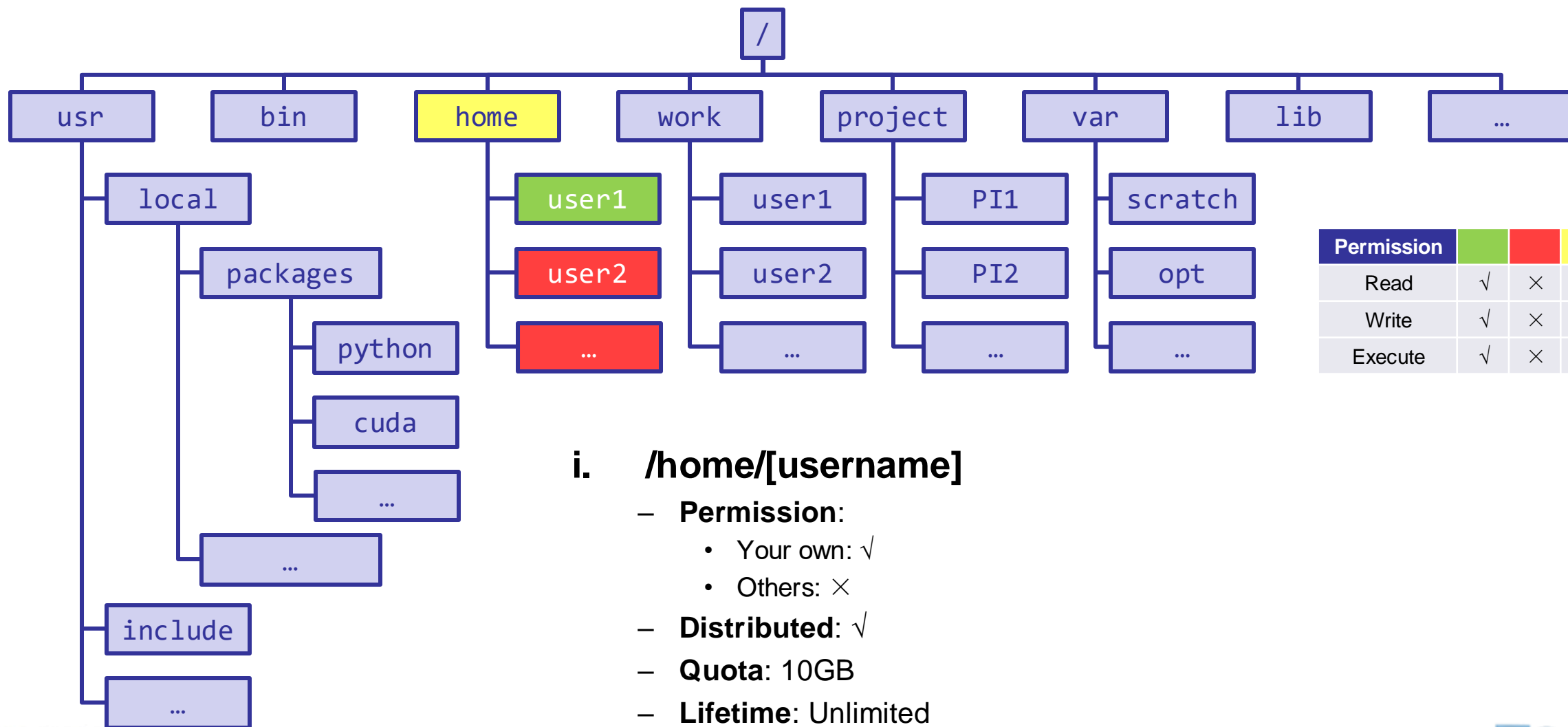

Permission	Green	Red	Yellow
Read	√	×	√*
Write	√	×	×
Execute	√	×	√*

## i. `/home/[username]`

- **Permission:**
  - Your own: √
  - Others: ×
- **Distributed:** √
- **Quota:** 10GB
- **Lifetime:** Unlimited
- **Best for:** Code / executables

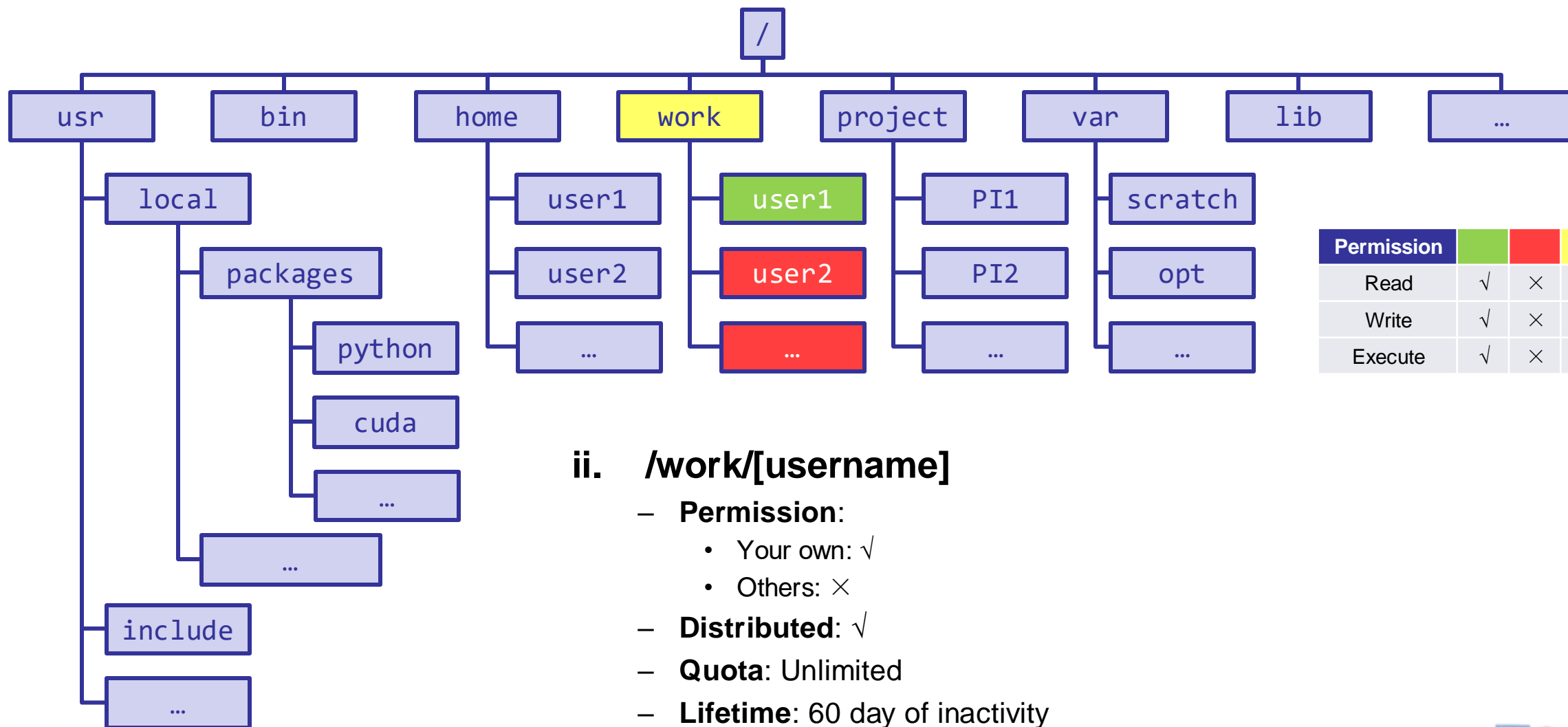

## ii. /work/[username]

- **Permission:**
  - Your own: √
  - Others: ×
- **Distributed:** √
- **Quota:** Unlimited
- **Lifetime:** 60 day of inactivity
- **Best for:** Job input / output

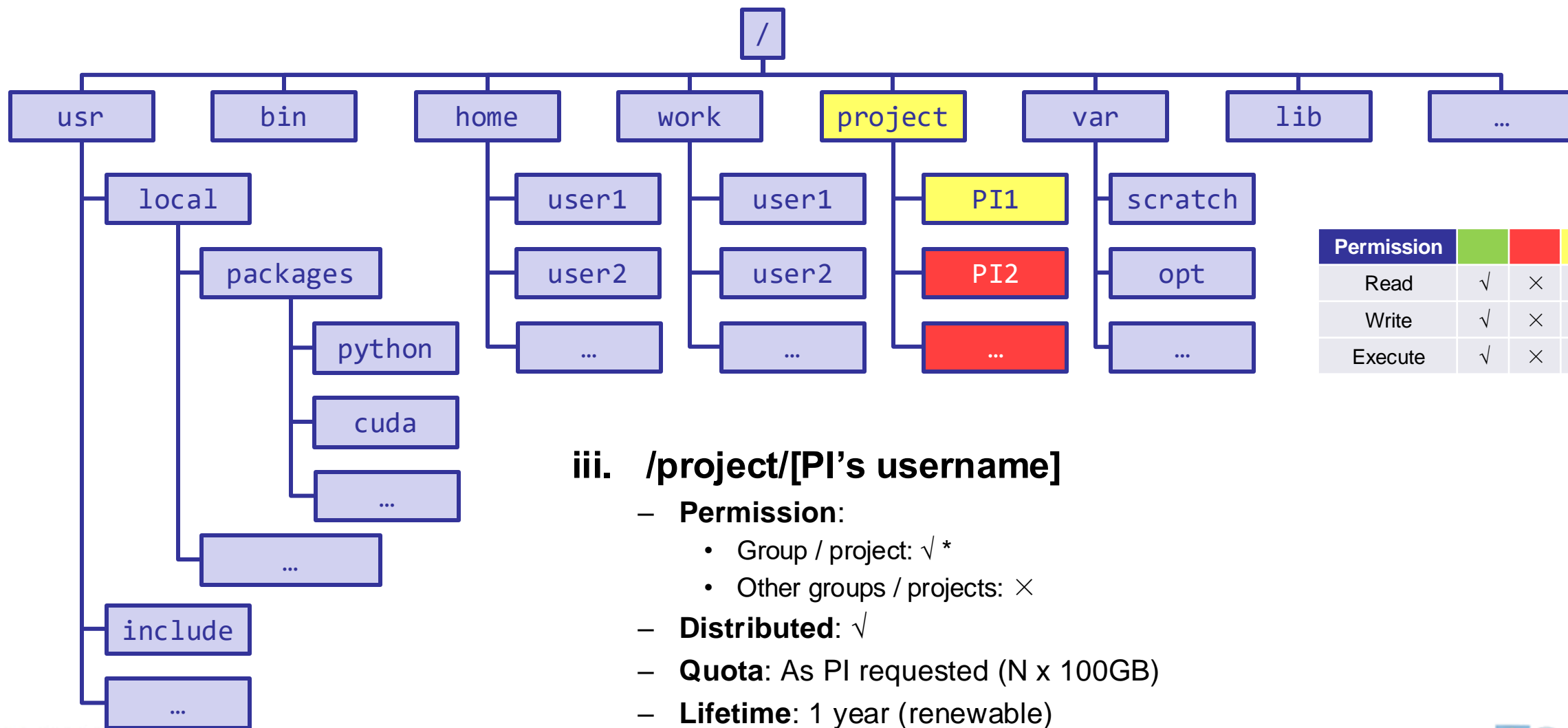

Permission	Green	Red	Yellow
Read	$\checkmark$	$\times$	$\checkmark^*$
Write	$\checkmark$	$\times$	$\times$
Execute	$\checkmark$	$\times$	$\checkmark^*$



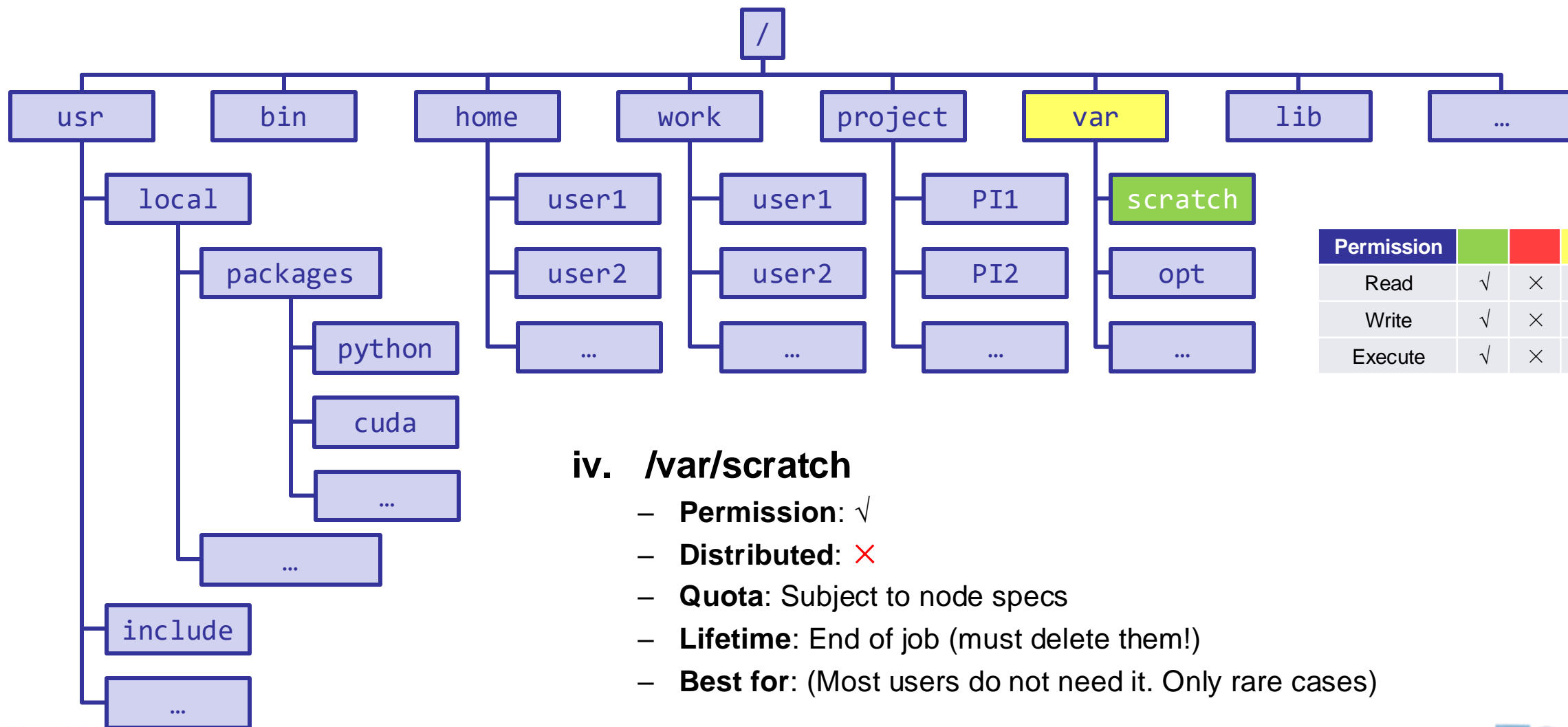

### iv. /var/scratch

- **Permission:** √
- **Distributed:** ×
- **Quota:** Subject to node specs
- **Lifetime:** End of job (must delete them!)
- **Best for:** (Most users do not need it. Only rare cases)

## File system summary

Directory (folder)	Distributed	Throughput	Lifetime	Quota	Best for
/home/[username]	√	Low	Unlimited	5GB (QB2) 10GB (others)	Code / executables
/work/[username]	√	High	60 days of inactivity	Unlimited	Job input/output
/project/[Pi's username]	√	Medium / High	1 year (renewable)	As PI requested (N x 100GB)	Specific project / group sharing. <b>NOT for archive!</b>
/var/scratch	×	High	End of job	Subject to node specs	(Most users do not need it. Only rare cases)

- **Tips**
  - **Neither /work nor /project** is for long-term storage
  - /work directory will be created **1 hour** after the first cluster login
  - /project directory: **Only PI w/ active allocations** can apply! (See appendix or contact us)
  - **Avoid** writing output to your home directory!
  - Check current disk quota and usage: **balance / showquota**

- File transfer

Commands	
scp / rsync	<p>From/to a Unix/Linux/Mac machine (including between the clusters)</p> <ul style="list-style-type: none"><li>• Syntax:<ul style="list-style-type: none"><li>- scp &lt;options&gt; &lt;source&gt; &lt;destination&gt;</li><li>- rsync &lt;options&gt; &lt;source&gt; &lt;destination&gt;</li></ul></li></ul>
wget	<p>From a download link on a website (usually opened with a web browser)</p> <ul style="list-style-type: none"><li>• Syntax:<ul style="list-style-type: none"><li>- wget &lt;link&gt;</li></ul></li></ul>

# 2) File system

- File transfer

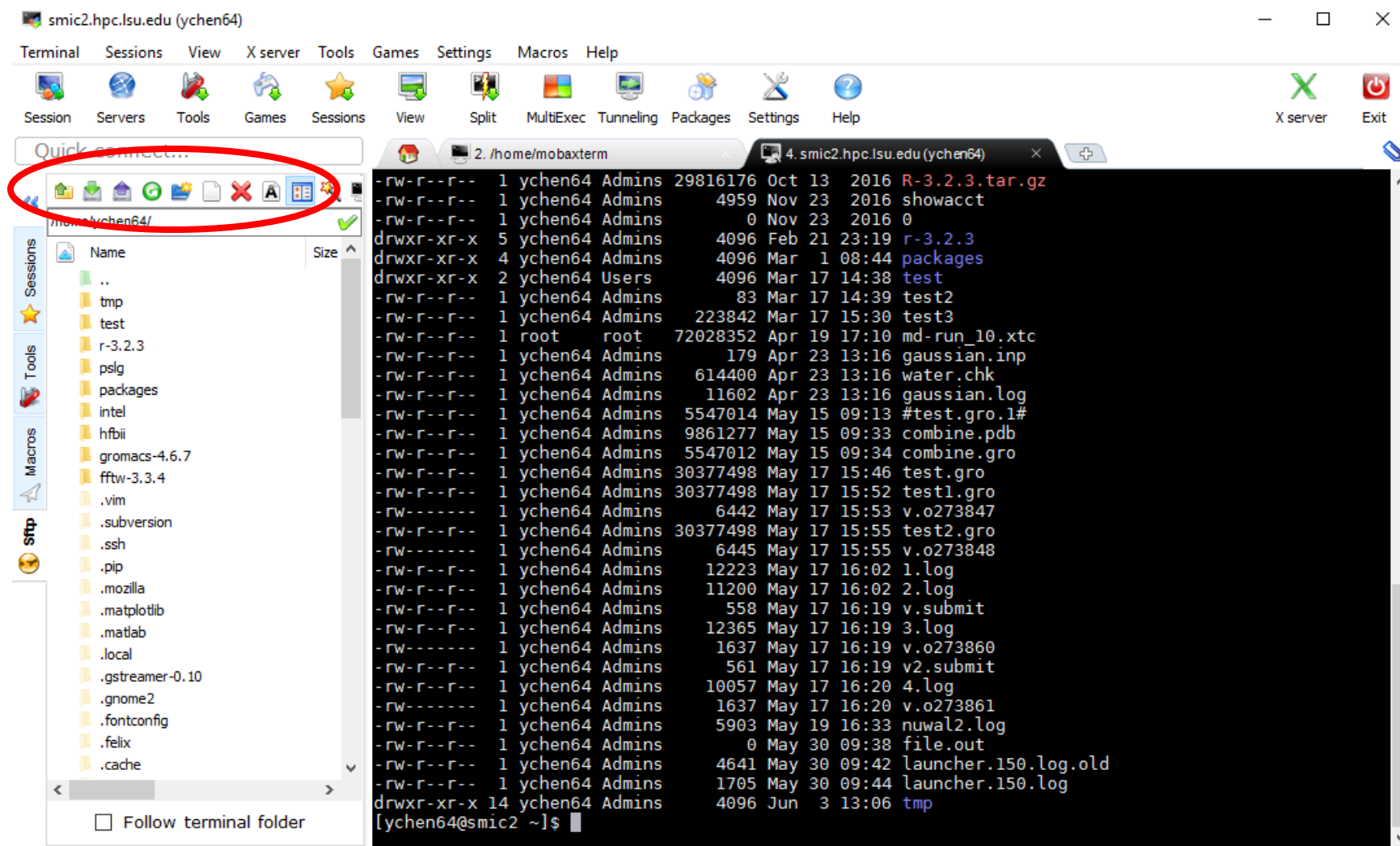

UNREGISTERED VERSION - Please support MobaXterm by subscribing to the professional edition here: <http://mobaxterm.mobatek.net>



- **HPC User Environment 1**

1. Intro to HPC
  - 1) Why HPC?
  - 2) What is HPC?
  - 3) Our HPC
2. Getting started
  - 1) Accounts
  - 2) Allocation
3. Into the cluster
  - 1) Getting connected
  - 2) File system
4. **Software environment**
  - 1) Preinstalled (modules)
  - 2) User installation

- **HPC User Environment 1**

1. Intro to HPC
  - 1) Why HPC?
  - 2) What is HPC?
  - 3) Our HPC
2. Getting started
  - 1) Accounts
  - 2) Allocation
3. Into the cluster
  - 1) Getting connected
  - 2) File system
4. **Software environment**
  - 1) Preinstalled (modules)
  - 2) User installation

# 1) Preinstalled (modules)

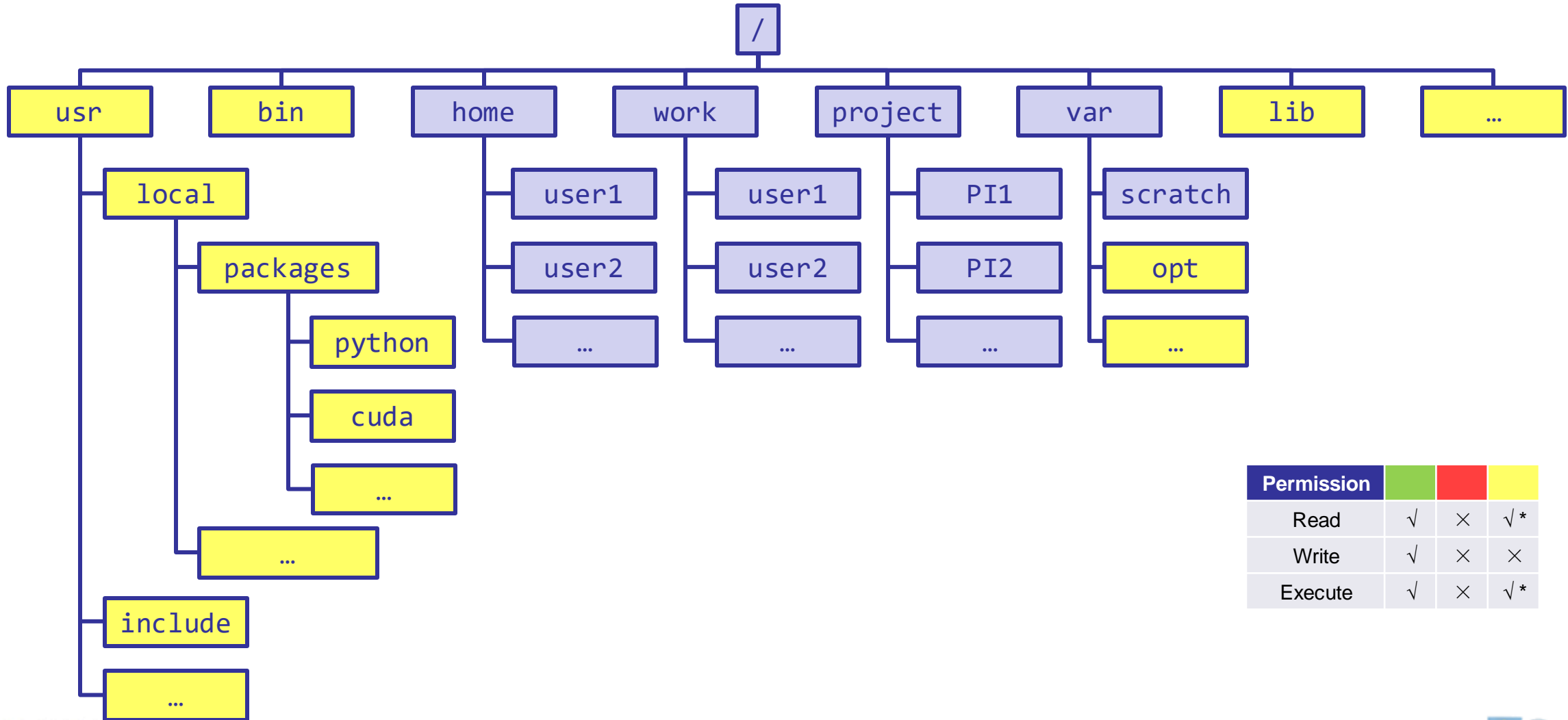

Permission	Green	Red	Yellow
Read	√	×	√*
Write	√	×	×
Execute	√	×	√*

# 1) Preinstalled (modules)

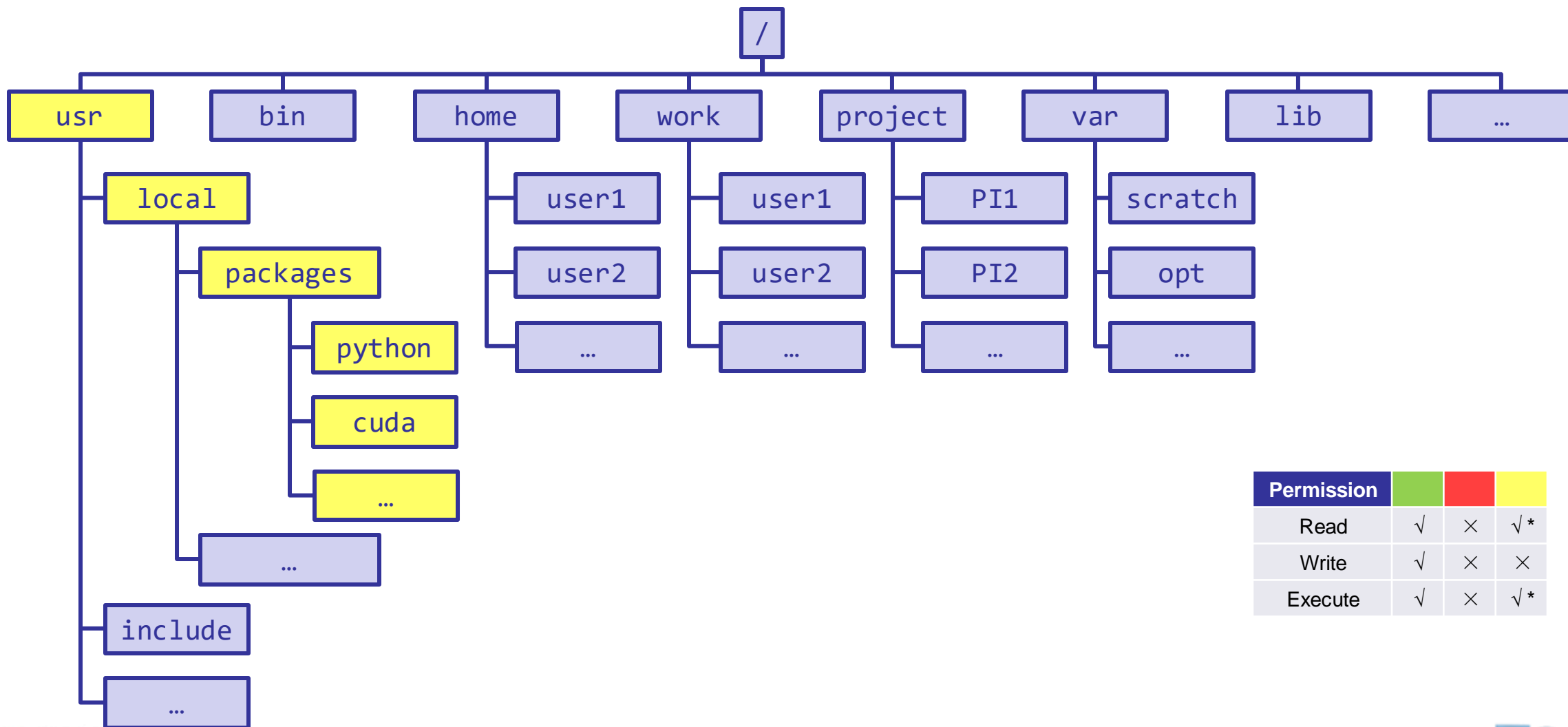

Permission	Green	Red	Yellow
Read	√	×	√*
Write	√	×	×
Execute	√	×	√*



# 1) Preinstalled (modules)

- **Modules**

- Software that **can be loaded / unloaded** on demand.
- List of modules **preinstalled system-wide**: <https://www.hpc.lsu.edu/docs/guides/index.php>

Category	Modules
Mathematical & utility	FFTW, HDF5, NetCDF, PETSc ...
Applications	Amber, NWChem, NAMD, Gromacs, R, LAMMPS ...
Visualization	VisIt, VMD, Paraview ...
Programming Tools	Totalview, DDT, TAU ...

# 1) Preinstalled (modules)

- **Modules**

## Useful commands

<code>module available</code> ( <code>module av</code> )	List available modules on the cluster
<code>module list</code> ( <code>module li</code> )	List currently loaded modules
<code>module load [module name]</code>	Load module(s)
<code>module unload [module name]</code>	Unload module(s)
<code>module swap/switch [module 1] [module 2]</code>	Unload a Module 1 and load Module 2
<code>module purge</code>	Unload all modules
<code>module display [module name]</code>	Display module information and all environmental variables changes when loaded

# 1) Preinstalled (modules)

- **Modules**

- Auto-load modules: `~/.modules`

- **HPC User Environment 1**

1. Intro to HPC
  - 1) Why HPC?
  - 2) What is HPC?
  - 3) Our HPC
2. Getting started
  - 1) Accounts
  - 2) Allocation
3. Into the cluster
  - 1) Getting connected
  - 2) File system
4. **Software environment**
  - 1) Preinstalled (modules)
  - 2) User installation

# 2) User installation

You can't...	You can...

You can't...	You can...
<ul style="list-style-type: none"><li>• yum / apt-get</li><li>• sudo (!!!)</li><li>• ...</li></ul>	

You can't...	You can...
<ul style="list-style-type: none"><li>• yum / apt-get</li><li>• sudo (!!!)</li><li>• ...</li></ul>	<ul style="list-style-type: none"><li>• Build from source</li><li>• Use virtual environment (e.g., conda) *</li><li>• Advanced methods (e.g., Singularity) *</li><li>• Ask HPC staff for help</li><li>• ...</li></ul>

- **Recommended paths:**
  - a) /home (for yourself)
  - b) /project (for group sharing or large applications)



- **Two types of software packages:**
  - Preinstalled (modules)
  - User installed

## ■ HPC User Environment 1

### 1. Intro to HPC

- 1) Why HPC?
- 2) What is HPC?
- 3) Our HPC

→ **LSU HPC (SMIC, Deep Bayou, SuperMike III) / LONI (QB2, QB3)**

### 2. Getting started

- 1) Accounts
- 2) Allocation

→ **Need an account sponsor! Most likely a faculty**

→ **Request a new one or join an existing one**

### 3. Into the cluster

- 1) Getting connected
- 2) File system

→ **Logging in via SSH; Do NOT run jobs on head node**

→ **Know your /home, /work, /project**

### 4. Software environment

- 1) Preinstalled
- 2) User installation

→ **Use modules**

→ **No sudo or yum**

- **HPC User Environment 2**

1. Queuing system
2. How to run jobs

- **Contact user services**

- Email Help Ticket: [sys-help@loni.org](mailto:sys-help@loni.org)
- Telephone Help Desk: +1 (225) 578-0900

- **Storage allocation  $\neq$  computing allocation (what we talked about today)**
- **PI can apply for extra disk space on the /project volume for you and his/her entire research group if**
  - your research requires some files to remain on the cluster for a fairly long period of time; **and**
  - their size exceeds the quota of the /home
- **The unit is 100 GB**
- **Storage allocations are good for 1 year, but can be extended based on the merit of the request**
- **Examples of valid requests**
  - I am doing a 12-month data mining project on a large data set
  - The package I am running requires 10 GB of disk space to install
- **Examples of invalid requests**
  - I do not have time to transfer the data from my scratch space to my local storage and I need a temporary staging area

- **An example of a simple module file (`~/my_module/gitkey`):**

```
#!/Module
proc ModulesHelp { } {
    puts stderr { my compiled version of git.
}
}
module-whatism {version control using git}
set GIT_HOME /home/fchen14/packages/git-master/install
prepend-path PATH $GIT_HOME/bin
```

- **Add the path to the key to the `MODULEPATH` environment variable:**

```
$ export MODULEPATH=~/my_module:$MODULEPATH
```

- **Then try to use:**

```
$ module load gitkey
$ which git
$ module unload gitkey
$ which git
```

- 1. <https://www.4freephotos.com/CPU-schematic-6037.html>
- 2. [https://en.wikipedia.org/wiki/Apple\\_A16#/media/File:Apple\\_A16.jpg](https://en.wikipedia.org/wiki/Apple_A16#/media/File:Apple_A16.jpg)
- 2. [https://www.cpu-monkey.com/en/cpu-apple\\_a16\\_bionic](https://www.cpu-monkey.com/en/cpu-apple_a16_bionic)